

UPAIRONE

Instruction Manual



UPAIR¹



Contents

Contents	1
Instructions Before Use	2
A General Introduction	3
Aircraft	3
Aircraft Parameter	3
Indicator Descriptions	4
Remote Controller	4
Operation of the Remote Controller(American Mode)	5
The Parameter of the Remote Controller and Real-time FPV	6
FPV Screen	6
OSD Interface	6
Instructions for Use	6
Charging the Remote Controller	7
Gimbal	8
Gimbal Parameter	8
Attaching the Camera to the Gimbal	8
Camera	9
Camera Parameter	9
Intelligent Battery	9
The parameter of the Intelligent Battery	9
Functions of the Intelligent Battery	10
Charging the Intelligent Battery	10
Battery Level Indicator Status	10
Cautions Regarding the Use of the Intelligent Battery	10
Before a Flight	11
Installing the Propellers	11
Switching on the Remote Controller and FPV Monitor	11
Installing and Powering on the Intelligent Battery	12
Starting the Motors(American Mode)	12
About the Flight	13
Stopping the Motors(American Mode)	13
Cautions Before/During a Flight	14
Failsafe Function	14
Auto Return Triggered by Low Voltage	14
Failsafe Auto Return	14
Auto Return Function	14

Instructions Before Use

Before using this product, please thoroughly and carefully read the entire manual and operate aircraft in accordance with the following instructions:

1. Before each flight, please make sure you have fully understood and will obey local laws and regulations.
 2. Please check if all the accessories and/or components are ready for use and in good condition, otherwise, please do not operate aircraft.
 3. Please install the propellers in accordance with the instructions and make sure they are correctly and firmly installed, so as to prevent propellers from falling off the aircraft during the flight, which may cause unexpected damage.
 4. Before each flight, please make sure the remote controller, the camera and the aircraft are fully powered.
 5. It is advised to operate aircraft in open areas, away from buildings, high-voltage power lines, in order to avoid interference between the remote controller and communication base stations, Wi-Fi etc.
 6. Before each flight, please power on the remote controller before switching on the aircraft; After the landing, please power off the aircraft before switching off the remote controller.
 7. Before each flight, please make sure the aircraft is kept clear of any objects and/or persons within a radius of 10m, and keep the aircraft away from obstacles such as crowds, high-voltage power lines, trees and water surface etc.
 8. During the entire process of descending, please keep the aircraft stable ;When it closes to the ground, it is advised to make it loiter for a few seconds before the ground is confirmed flat and smooth, then make it slowly descend to the ground. The locking process may take ten or more seconds, please be patient.
 9. Please don't fly the aircraft under harsh weather conditions like strong wind, heavy snow or rain or thick fog etc.
 10. Please do not operate the aircraft in restricted areas or no-fly zones under relevant laws and/or regulations, airport for example.
 11. Please do not operate the aircraft when you are in poor mental state(such as intoxication).
 12. Please keep the aircraft, accessories and components out of children's reach; In case any accessories and /or components are swallowed by a child, he or she should be immediately taken to a doctor for treatment.
 13. If the aircraft is to be left idle for a long period, please take out the battery, place the aircraft in an environment free from dampness, moisture, mould, avoid exposing to strong sunlight and also out of electromagnetic interference.
 14. UPair shall assume no responsibility and/or liability for any consequences resulting from unauthorized mounting/dismounting, assembly/disassembly and/or modification of aircraft.
- Much thanks for your purchasing UPair product. Please use the product in strict compliance with this manual.
- This product and the intellectual property right of the manual belong to UPair, without written permission from UPair, no organization or individual is permitted to reprint, copy or distribute any contents of this manual in any forms.
- If you have any questions or problems when using this product, please contact UPair authorized distributors or UPair Customer Service.

A General Introduction

Aircraft

UPair One is a quadcopter researched by Gten Innovation Company, which equips with a built-in flight control system, a gimbal and a camera. Despite the basic functions as ascending and descending, it's also capable of shooting, video recording, one key return, failsafe auto return, and auto return triggered by low battery voltage.

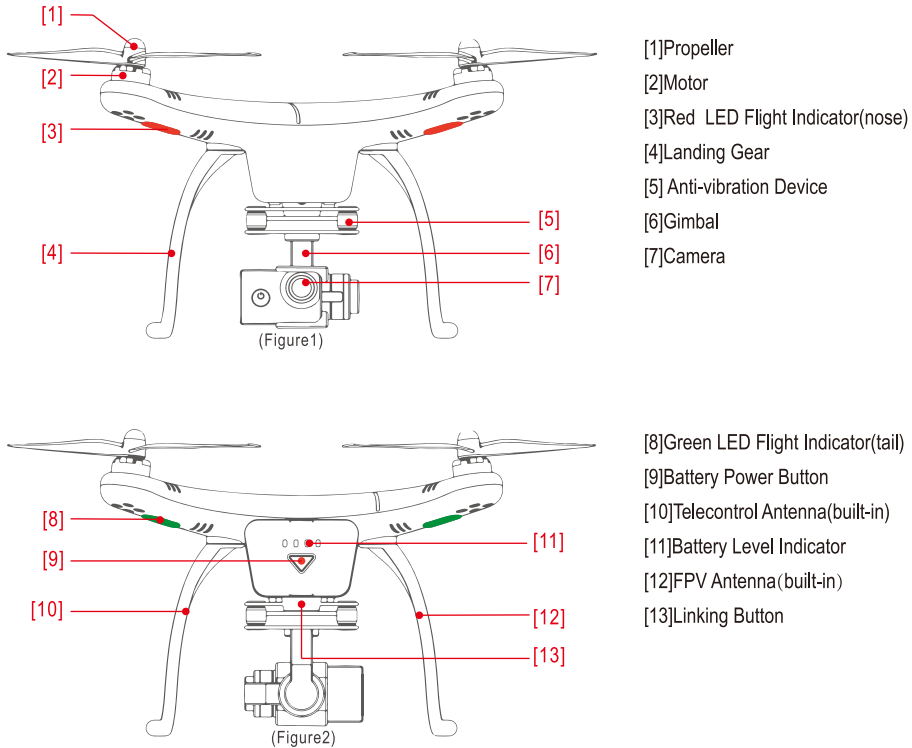

Aircraft Parameter

Total Weight	1350g	Max Vertical Speed	4.5m/s
Height (with landing gear)	220mm	Max Tilt Angle	45°
Wheelbase	355mm	Max Pan Speed	14m/s
Propeller	9450	Hovering Accuracy (during a safe flight)	Vertical: 1m Horizontal: 1.6m
Motor	2212		
Loitering Duration	Full-load(1350g): 19minutes; Aircraft alone(1085g): 25minutes		

Indicator Descriptions

The LED flight indicators on the aircraft arm indicate the directions of the aircraft. When the aircraft is powered on, the LED indicators light up. The red indicator represents the nose while the green indicator represents the tail.





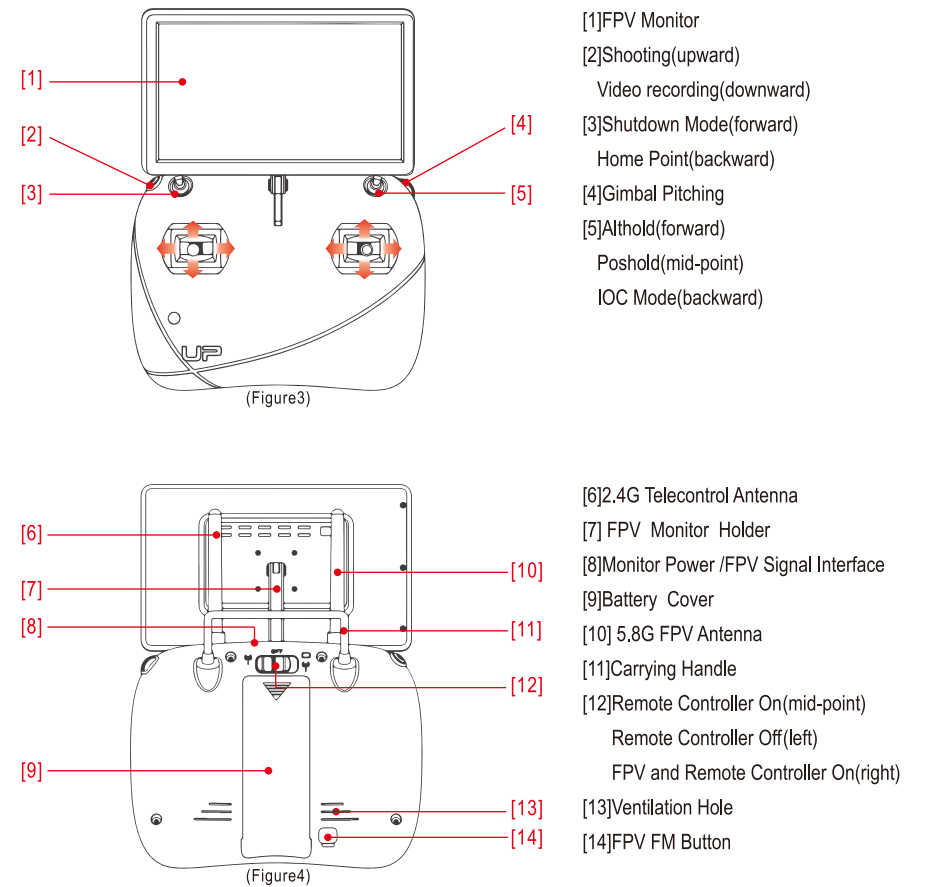

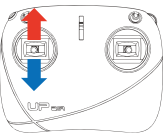
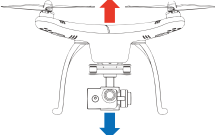
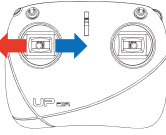
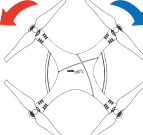
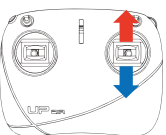
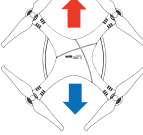
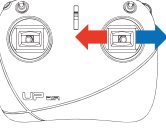
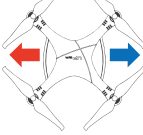
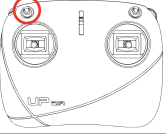

Remote Controller

The remote controller is integrated with a 2.4G telecontrol transmitter, a seven-inch screen and a 5.8G FPV receiver. The link between the remote controller and the receiver has been established. The remote controller is set to Mode 2 by default.

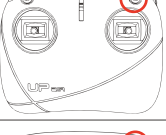

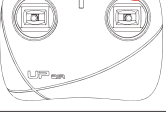
[8] is a specially designed interface for Upair FPV, into which no other device is allowed to be inserted

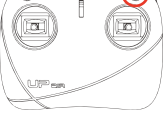
Operation of the Remote Controller(American Mode)

Remote Controller	Aircraft	Althold/Poshold/IOC Mode
		Push up the joystick on the left(illustrated as the red arrow) to make the aircraft ascend. Pull down the joystick on the left(illustrated as the blue arrow) to make the aircraft descend.
		Push the joystick leftward(illustrated as the red arrow) to make the aircraft rotate counter clock-wise. Push the joystick rightward(illustrated as the blue arrow) to make the aircraft rotate clock-wise. The aircraft has a maximum rotating angular velocity of 200°/s.
		Push up the joystick on the right (illustrated as the red arrow) to make the aircraft tilt and fly forward. Pull down the joystick on the right(illustrated as the blue arrow) to make the aircraft tilt and fly backward.
		Push the joystick leftward (illustrated as the red arrow) to make the aircraft tilt and fly leftward. Push the joystick rightward (illustrated as the blue arrow) to make the aircraft tilt and fly rightward. The aircraft has a maximum tilt angle of 30°.
Remote Controller	Switch Positions	Flight Mode
	Front L Back 	Home Point Mode Pull the switch backward(as illustrated in the left figures) to make the aircraft enter Home Point Mode, then it will fly back to the take-off point.
	Front L Mid  Back 	Althold Mode Push the switch forward(as illustrated in the left figures) to make the aircraft enter Althold Mode, in which the aircraft will fly in the current altitude.
	Front L Mid  Back 	Poshold Mode Set the switch to the mid-point(as illustrated in the left figures) to make the aircraft enter Poshold Mode, in which the aircraft will maintain its current position.
	Front L Mid  Back 	IOC Mode Pull the switch backward(as illustrated in the left figures) to make the aircraft enter IOC Mode, in which the aircraft is made to perform pitching, ascending/descending, rotating, tilting etc by the corresponding buttons of the remote controller, regardless of where the nose of the aircraft is facing, so the user can operate it freely.

The Parameter of the Remote Controller and Real-time FPV

Total Weight	826g	Battery Voltage	11.1V
Number of Channels	10	Battery Capacity	2200mAh
Telecontrol Antenna Frequency	2.4GHz	Communication Range of RC	About 1km
FPV Frequency	5.8GHz	Communication Range of FPV	About 1km

Linking Procedures:When the remote controller and the aircraft are powered on, hold down the “FPV FM”button on the back of the remote controller ,the indicator blinks ,indicating the auto linking is started; When the indicator changes to solid green,then the linking is successfully established. When two or more quadcopters are operated at the same time, if the frequency points are in conflict, it is advised to reestablish the linking, please press the “Linking” button(refer to Figure2) of the aircraft to change to another channel,then hold down the “FPV FM”button on the back of the remote controller, when the current images on the FPV screen are confirmed to be streamed down from your aircraft, it indicates the linking is successfully established.

FPV Screen

UPair One Remote Controller is equipped with a built-in 5.8GHz FPV receiver, which works correspondingly with a built-in 5.8GHz transmitter of the aircraft, so the real-time images can be streamed from the camera to the FPV screen

OSD Interface

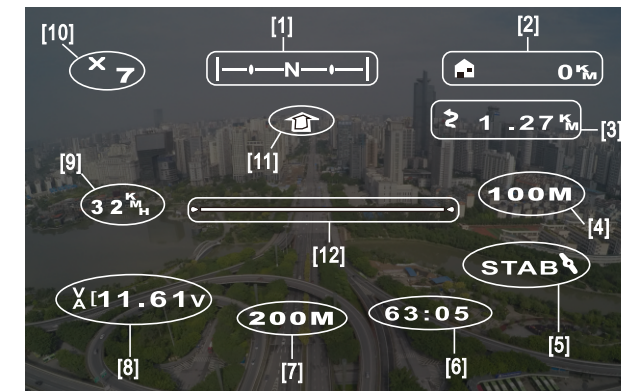

(Figure5)

Note: When the aircraft, remote controller and FPV are switched on, the self-examining process of the flying altitude is displayed on OSD interface, “the flying altitude” rises, then drops to a constant figure; After this, it is advised to unlock the aircraft (refer to page 12) to ensure a stable flight.

- [1]Nose Direction
- [2]Home Distance
- [3]Total Cruising Range
- [4]Flying Altitude
- [5]Flight Mode
- [6]Time
- [7]Altitude
- [8]Voltage
- [9]Flight Speed
- [10]Number of Satellites
- [11]Home Direction
- [12]Aircraft Attitude Line

Instructions for Operating

Shooting :When the “Shooting” button is pressed , a small icon (shown in Figure6) appears on the FPV screen, indicating the camera has entered the shooting mode.

Video Recording: When the “Video Recording” button is pressed , a small icon (shown in Figure7) appears on the FPV screen, indicating the camera has entered the video recording mode.



(Figure6)



(Figure7)

Charging the Remote Controller

1. Slide down the rear cover of the RC battery compartment(Figure10), pull the battery out.
2. Charge the RC battery(Figure8) by connecting the RC battery with the charger(Figure9).
3. When the charger indicators turn red ,it indicates charging is in process ;when the charger indicators turn green, it indicates the battery has been fully charged. If the charger indicators blink red and green, it indicates the charger has been powered, but has not been correctly connected with the battery.
4. Disconnect the RC battery with the charger when it is fully charged, then put the battery into the battery compartment.

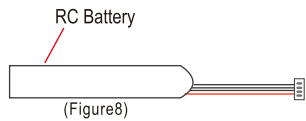

(Figure8)

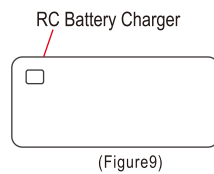

(Figure9)

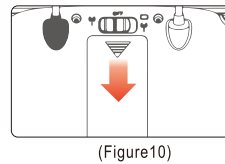

(Figure10)

Gimbal

Powered by a flight intelligent battery , the UPair One two-axis stabilization gimbal is designed for carrying a camera; Gimbal angle can be adjusted by the corresponding button of the remote controller during a flight.

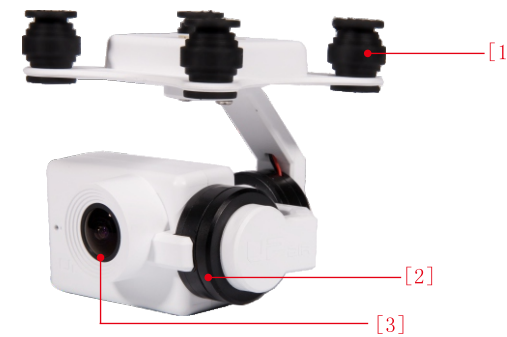

(图11)

- [1]Anti-vibration Device
- [2]Gimbal Motor
- [3]Camera

Gimbal Parameter

Angle Control Precision	$\pm 0.2^\circ$	Operating Voltage	11.1V
Rotational Range	Pitching $-30^\circ \sim 90^\circ$	Maximum Control Speed	Pitching $15^\circ/s$

Camera

Powered by the flight intelligent battery, UPair One camera proper has the function of shooting and video recording, which can also be done by the corresponding buttons of the remote controller. Camera supports single shooting and HD 1080P video.

Camera Parameter

Weight	70g	Camera Lens	SONY Lens (2K/4K)
Dimension	59x41x21mm	Video/Photo Format	*.MOV / *.JPG
Battery Capacity	900mAH	Working Voltage	5V
Supported Maximum TF Card	32G	Functions	Shooting, Video recording,
Charging Time	2~3 h		

Intelligent Battery

UPair One is powered by an UPair approved intelligent lithium battery which has a full capacity of 5400mAh and a voltage of 11.1V; It must be charged with an UPair approved charger.

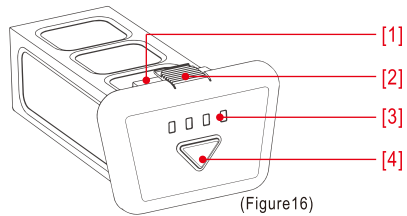

(Figure16)

- [1]Charging Interface
- [2]Battery Box Clip
- [3]Battery Level Indicator
- [4]Power Switch

Intelligent Battery Parameter

Battery Type	Lithium Battery	Charging Time	1~1.5h
Capacity	5400mAh	Environment Temperature for Charging	0°C ~ 40°C
Voltage	11.1V	Environment Temperature for Discharging	-20°C ~ 50°C

Functions of the Intelligent Battery

Checking Battery Level: short press the “power switch” button when the battery is off.

Powering On the Intelligent Battery: when the battery is off, short press the “power switch” button, then hold down the button for at least 2s to power on the battery.

Powering Off the Intelligent Battery: when the battery is on, short press the “power switch” button, then hold down the button for at least 2s to power off the battery.

Charging the Intelligent Battery

Please connect the charger plug (Figure18) to the charging interface(Figure17) of the battery, when the battery level indicators blink green in sequence from left to right, it indicates charging is in process; when the battery level indicators stop blinking and go out, it indicates the battery has been fully charged.

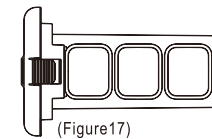

(Figure17)

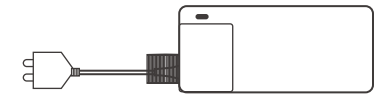

(Figure18)

Battery Level Indicator Status

Battery Level	Battery Level Indicator Status
100%	● ● ● ●
75%	● ● ● ○
50%	● ● ○ ○
25%	● ○ ○ ○

⚠ Cautions Regarding the Use of the Intelligent Battery:

- Please immediately charge the intelligent battery and the remote controller after unpacking, always use UPair approved charger .
- When the current battery has been charged and discharged over 300 times, please replace it with a new one; If the battery is to be left idle for a long period, please make sure the battery capacity is below 50% when the storage begins.
- It is advised to thoroughly charge and discharge the battery once when it has been charged and discharged 20 times or so.
- Please use or store the battery in a fireproof location, otherwise it might result in battery overhear , fire, explosion, or cause other damage.
- In case electrolytic solution spurts into your eyes, please immediately wash your eyes and go to see a doctor.
- Never dispose of a battery irresponsibly, please thoroughly discharge the battery and make it insulated before throwing it into a special recycle bin.

Before a Flight

Installing the Propellers

1. Match the black-nut propeller with the motor with a hole in the center, then tighten the propeller by screwing it down counter clock-wise.(Figure19)
2. Match the grey-nut propeller with the motor without a hole in the center, then tighten the propeller by screwing it down clock-wise.(Figure20)

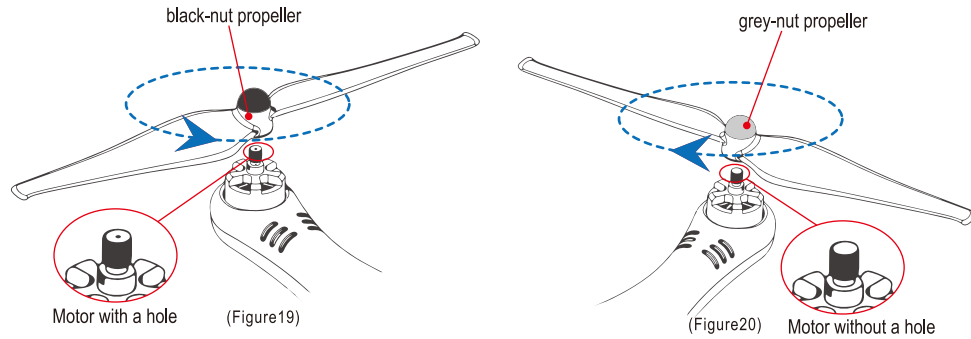

Switching on the Remote Controller and FPV Monitor

On the back of the remote controller, there is a switch set at the left by default, you can switch on the remote controller and FPV monitor by pushing the switch rightward.(Figure21)

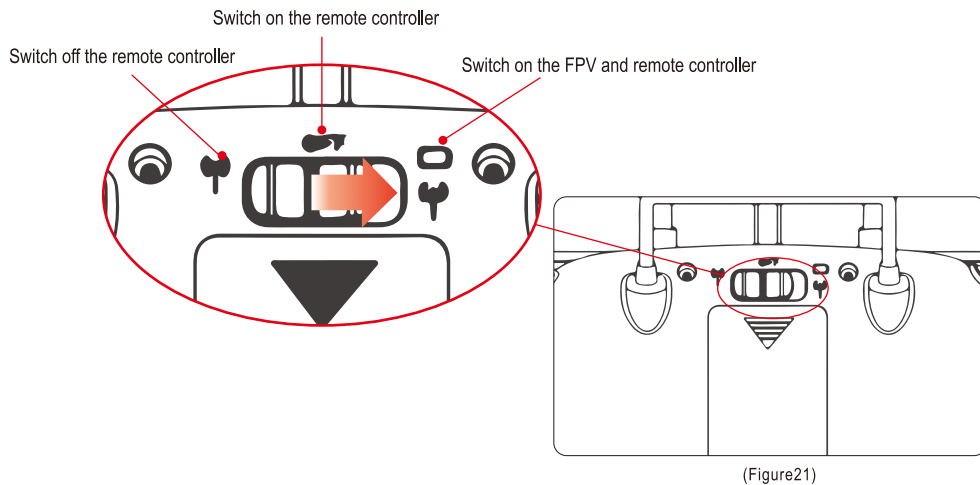

Installing and Powering on the Intelligent Battery

1. Push the battery into the battery compartment(Figure22) until you hear a sound "click", make sure the battery is tightly and correctly placed in the battery compartment.
2. When the battery is off , short press the power switch(Figure23), then hold the button down for at least 2s to power on the battery.
3. When the power is on, aircraft will display self-examing process, you can hear a sound "beep-beep". Do not move your aircraft during this process.

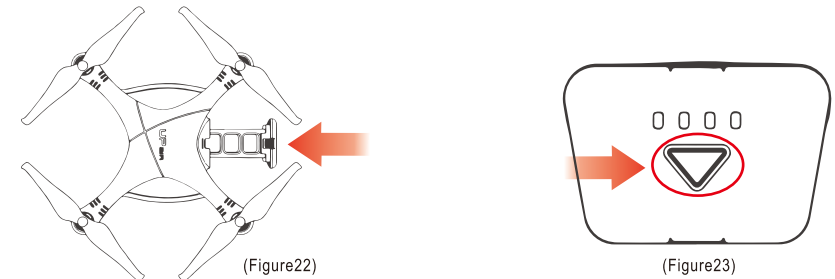

Starting the Motors (American Mode)

[Mode2] Starting the Motors : When the aircraft opened up, please first display self-examing process of flying altitude. Then you can push both joysticks to the inside bottom corner or outside bottom corner to unlock the motor. Let go the joysticks when aircraft has been started.

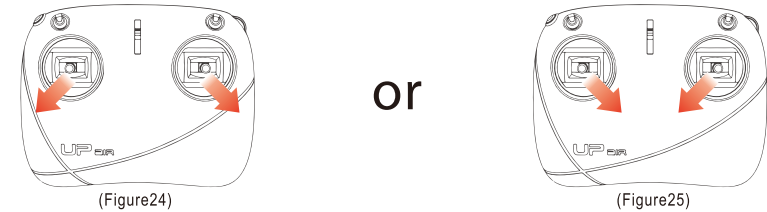

About the Flight

Now you can start your flight, please strictly follow the instructions above (refer to page 5) to ensure a safe flight. In order to minimize misoperation, dead space has been made for the joystick of the throttle and direction, including throttle-up:10%, throttle-down:10%; direction-left:5%, direction-right: 5%.

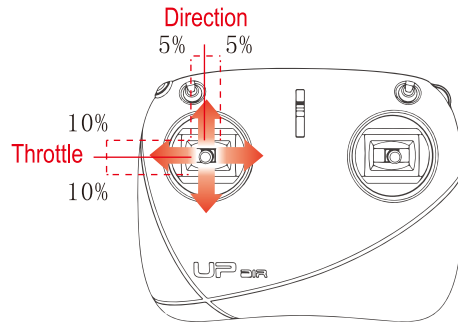

(Figure26)

Stopping the Motors (American Mode)

During the entire process of descending, please keep the aircraft stable: When it closes to the ground, it is advised to make it loiter for a few seconds before the ground is confirmed flat and smooth, then make it slowly descend to the ground. The locking process may take several seconds.

Stopping the Motors: When the aircraft is opened up, push the left joystick to the bottom side slowly and wait for ten seconds. When the lock order executed, the motors will stop immediately.

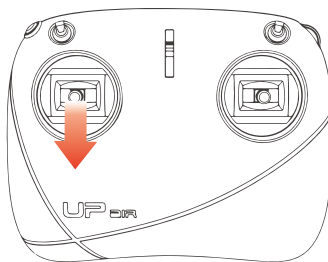

(Figure27)

⚠️ Cautions Before/During a Flight:

- Before each flight, please make sure the remote controller and the intelligent battery have sufficient power, and check if the propellers, the intelligent battery, the camera and the Micro-SD card have been securely and correctly installed.
- Before starting a flight, please switch on the remote controller before powering on the aircraft; After the landing, please power off the aircraft before switching off the remote controller.
- It is advised to operate the aircraft in open areas away from high-rise buildings, avoiding interference between the remote controller and communication base stations, Wi-Fi, high-voltage power lines etc.
- When operating the aircraft, please keep the aircraft away from obstacles, crowds, high-voltage power lines, trees and water surface etc.
- Please do not operate the aircraft under harsh weather conditions like strong wind, heavy snow or rain, thick fog etc.
- Please do not operate the aircraft in restricted areas or no-fly zones under relevant laws and/or regulations.

Failsafe Function

Auto Return Triggered by Low Voltage

During a flight, when the battery voltage is depleted to 10.6V or less, the "Auto Return" function will be triggered, which will make the aircraft fly back to the take-off point.

Failsafe Auto Return

- During a flight, when the communication between the aircraft and the remote controller is interrupted, the aircraft loiters for 3s where the communication fails; During this brief moment of 3s, if the communication still can not be reestablished, the aircraft will return automatically.
- During the process of auto return, if the communication between the aircraft and the remote controller is successfully reestablished, the aircraft loiters where the communication is reestablished, waiting for commands from the remote controller, then the operator can regain control of the aircraft.
- If the communication can not be reestablished during the entire process of auto return, the aircraft will fly back to the take-off point (When the remote controller is powered off, the failsafe auto return is triggered by default.)

Auto Return Function

- When the "Auto Return" function has been triggered, the aircraft will ascend to auto return altitude if current flying altitude is lower than setting value. Then it will fly back to the take-off point and land off.
- The aircraft will directly fly back to the take-off point and land off if current flying altitude is higher than setting value.