

EBV260BN

Blower Vac



User Manual

211927



Axminster Reference No:
EBV260BN Part No: 211927

www.axminster.co.uk

INTRODUCTION

EBV260BN engine blower has been designed and built to deliver superior performance and reliability without compromise to quality, compromise to quality, comfort, safety, or durability EBV260BN high performance engines represent the leading edge of 2-cycle engine technology, delivering exceptionally high power at remarkably low displacement and weight . As a professional owner/operator, you'll soon discover why EBV260BN is simple in a class by itself!

IMPORTANT!

The information contained in this manual describes available at the time of production. While every attempt has been made to give you the very latest information about your EBV260BN, there may be some differences between your machine and what is described here . We reserves the right to make changes in production without prior notice, and without obligation to make alterations to machines previously manufactured. Before using this product, consult local regulation noise restrictions and hours of operation.



CAUTION!

This EBV260BN engine machine is equipped with a speak-arresting muffler. Never operate this machine without both the muffler and spark arrestor installed and properly functioning!

CONTENTS

Attention Statements.....	3
Product Description.....	4
Specifications.....	4
Assembling the Machine.....	5
Mixing Fuel.....	8
Filling the Fuel Tank.....	9
Starting the Machine.....	10
Adjusting Engine Speed.....	13
Routine Maintenances.....	15
Storage.....	17
Troubleshooting.....	18

ATTENTION STATEMENTS

This manual contains special “attention statements” surrounded by boxes and preceded by the triangular Attention Symbol



WARNING!

A statement preceded by WARNING contains Information that should be acted upon to prevent serious bodily injury.



CAUTION!

A statement preceded by the word “CAUTION” contains information that should be acted upon to prevent machine damage.

Additional attention statements that are not preceded by the Attention Symbol are:

IMPORTANT!

A statement preceded by the word “IMPORTANT” is one that possesses special significance.

NOTE:

A statement preceded by word “NOTE” contains information that is handy to know and may make your job easier.



Read and follow this manual. Failure to do so could result in serious injury.



Wear eye and hearing protection at all times during the operation of this machine

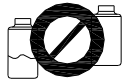

Do not operate this machine if you are tired, ill or under the influences of alcohol, drugs, or Medicine.

PRODUCT DESCRIPTION!

The operational procedures described in this manual are intended to help you get the most from your machine and to protect you and others from harm. These procedures are general guidelines only, and are not intended to replace any safety rules/laws that may be in force in your area. If you have any question regarding your EBV260BN blower & vacuum, or if you do not understand something in this manual, your dealer will be glad to assist you.



WARNING!

Do not make unauthorized Modifications to this machine

SPECIFICATIONS

Model	EBV260BN
Dimensions(L × W × H)	580 × 355 × 370
Engine Type	1E34FBN
Cylinder Diameter	34mm
Displacement	25.4cc
Fuel	Gasoline/oil mixture 40:1
Carburetor	Membrane type primer pump
Way of ignition	CDI
Spark plug	RCJ6Y
Starting	Recoil starter
Fuel Tank Capacity	0.5L
Weight	4.3kg

ASSEMBLING THE MACHINE

1. Assembling the vacuum

(1) Nomenclature

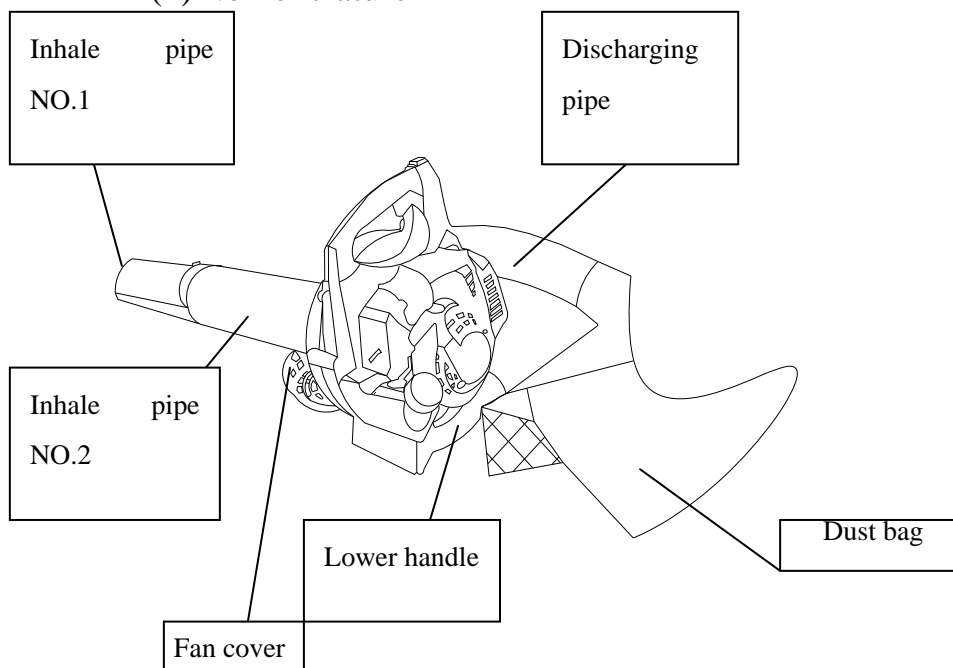

(2) Assembly

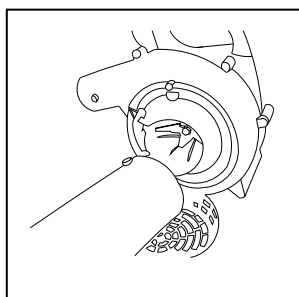

Open the fan cover,
connect inhale pipe
No.1 and No.2

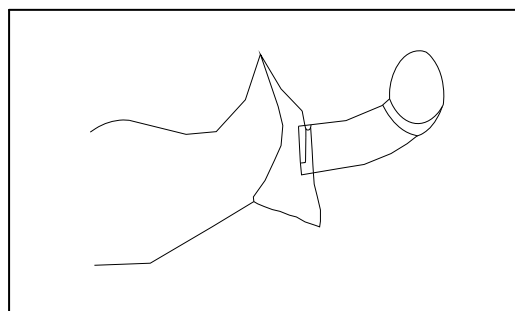

Insert discharging pipe into dust
bag from the jaws of the slide
fastener according to the picture
discharging pipe.

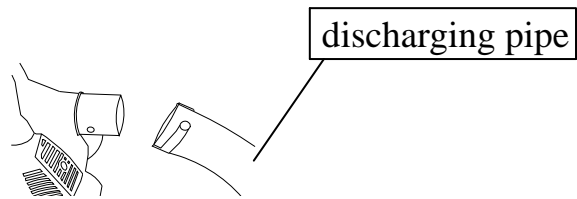

Put the discharging pipe to the machine.

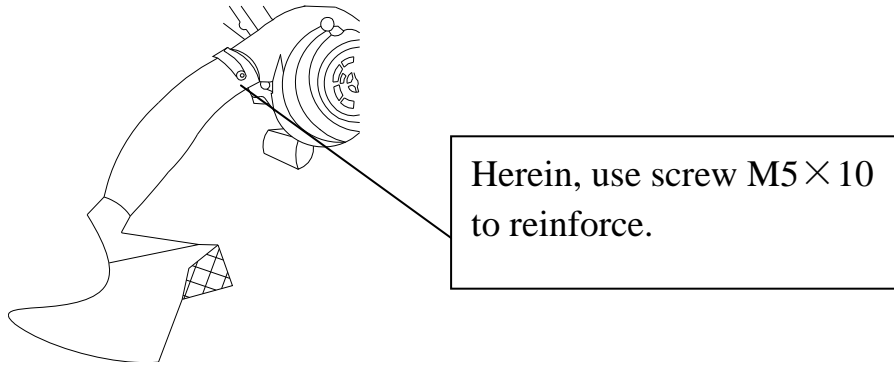

2. Install blower machine

(1) Terms

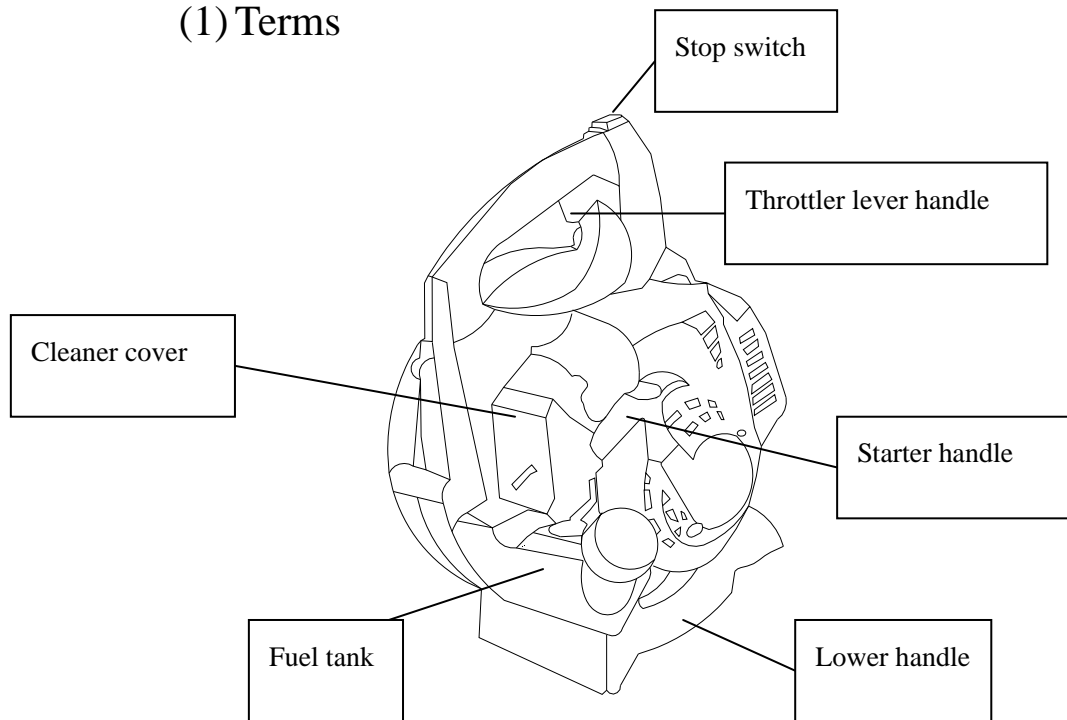

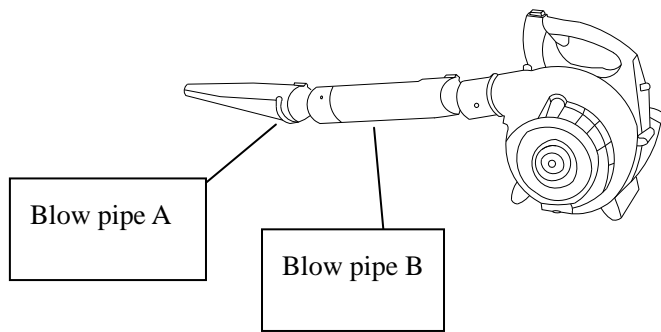

(2)Install

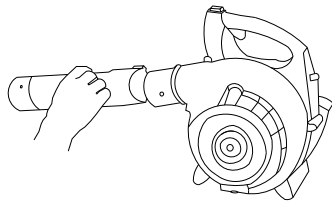

Put blow pipe B to the machine
by rotating

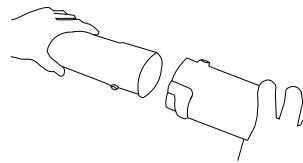

Put blow A to B by
rotating

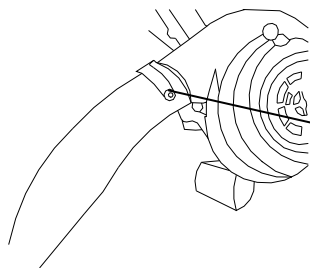

Use screw M5 × 10 to
reinforce

IMPORTANT!

Mix only enough fuel for your immediate needs! If fuel must be stored longer than 30-days, it should first be treated with a stabilizer or equivalent product!



WARNING!

Danger from rotating impeller! Stop the engine before installing or removing the machine tubes! Never perform any maintenance or assembly procedures on this machine while the engine is running.

MIXING FUEL

Fuel requirements

- Use only fresh, clean fuel
- Use only fuel with an octane rating of 90 or high
- Mix all fuel with premium 2-cycles engine oil at a gasoline/oil ratio of 40:1



CAUTION!

Never attempt to mix fuel in the machine fuel tank! Always mix all fuels in a clean, approved container!

Some gasoline contain alcohol as an oxygenated! Oxygenated fuels may cause increased engine operating temperatures! Under certain conditions, alcohol-based fuels may also reduce the lubricating qualities of some mixing oils! Never use any fuel containing more than 10% alcohol by volume! When an oxygenated fuel must be used fuel containing an ether-based oxygenates such as MTBE is to be preferred over alcohol!

Whenever possible use 2-cycle oil or equivalent oil mixed at a 40:1 ratio. Be aware that generic oils and some outboard mixing oils may not be intended for use in high-performance air cooled 2-cycle engines, and should never be used in your engine machine.



WARNING

Danger of fire! Never transfer or store fuels in the presence Of combustible materials! Before starting the engine, always move the machine to a clear area at least 10-feet (3-meters) away form fuels and other combustible materials!

IMPORTANT!

Mix only enough fuel for your immediate needs! If fuel must be stored longer than 30-days, it should first be treated with a stabilizer or equivalent product!

FILLING THE FUEL TANK

Remove the fuel cup

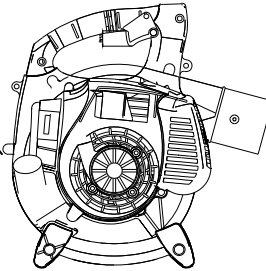

WARNING!

Danger of fire and burn injury!

- Always use extreme care when handling fuel! Fuel is highly flammable!
- Never operate this blower if fuel system components are damaged or are leaking!
- Never attempt to refuel the engine while it is running !
- Never attempt to refuel a hot engine! Always allow the blower engine to cool before fueling!

- Never smoke or light any fires near the blower or fuel!
- Always transport and store fuels in an approved container!
- Never place flammable material close to the engine muffler!
- Never operate the blower without a properly functioning muffler and spark arrestor installed!
- Never operate the blower unless it is properly assembled and in good working condition!

1. Place the machine on the ground or on a sturdy work surface, and wipe any debris from around the fuel cap.
2. Remove the fuel cap.
3. Fill the tank with clean, fresh fuel.
4. Replace the cap, and wipe away any spilled fuel before starting the machine.

STARTING THE MACHINE



WARNING!

Danger from rotating impeller! The impeller will rotate whenever the machine is operated! Never operate this machine unless the intake cover and machine tubes are properly installed and in good working order!

Danger from thrown dust or debris! Always wear eye protection when operating this machine! Never direct the machine stream toward people or animals!

Never operate this machine unless all controls are properly installed and in good working order!



WARNING!

The recoil starter can be damaged by abuse!

<Never pull the starter cord to its full length!

<Always engage the starter before cranking the engine!

<Always rewind the starter cord slowly!

Never operate the machine if the tubes are missing or damaged

Starting procedure

1. Prime the fuel system by repeatedly depressing the fuel primer bulb until no air bubbles are visible in the fuel discharge line.
 2. Cold engine only. Choke the engine by pulling the choke control to the fully extended position (choke is closed)
 3. Place the machine on the ground, and hold the machine handle firmly with your right hand .
 4. Pull the starter cord slowly until you feel the engine.
 5. Start the machine by pulling the starter cord upward rapidly.
- If necessary, repeat step 5 two or three times until the engine starts.

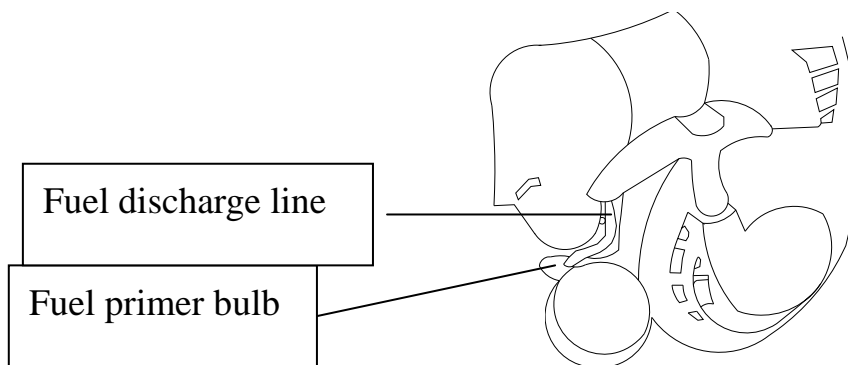

When the engine starts

IMPORTANT

For maximum vacuum performance and operating life, allow the engine to warm before use.

1. Run the engine at idle speed until operating temperature is reached(2 to 3 minutes)
2. As the engine warms, open the choke gradually by slowly pushing the choke control in to the fully retracted position.
3. The machine should now be ready for use.

If the engine dose not start

Repeat the appropriate starting procedures for “hot” or “cold” engine. If the engine still will not start, follow the “Starting a Flooded Engine” procedure (below).



WARNING!

Incorrect spark plug installation
Can result in serious engine
damage!

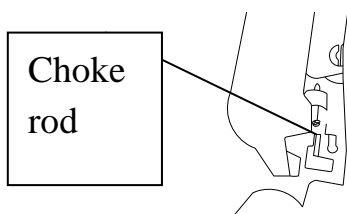

Starting a flooded engine

1. Disconnect the spark plug lead, and use the spark plug wrench to remove the plug in a counterclockwise direction.
2. If the spark plug is fouled or is soaked with fuel, clean or replace the plug as required.
3. Clean excess fuel form the combustion chamber by cranking the engine several times while the spark is removed.

4. Install the spark plug and firmly tighten it with the spark plug wrench. If a torque wrench is available, torque the spark plug to 148-165 inch-pounds. Reconnect the spark plug lead.
5. Repeat the starting procedures for “ warm engine”
6. If the engine still fails to fire or start, refer to the troubleshooting flowchart at the end of this manual.

ADJUSTING ENGINE IDLE SPEED

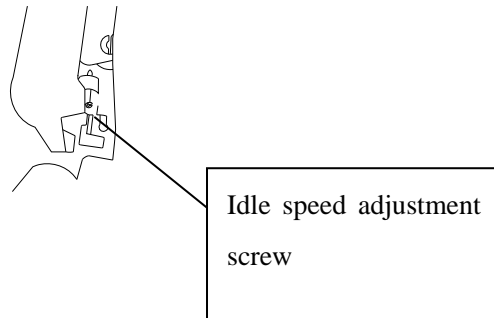

1. Start the engine by following the procedures described on the preceding pages.
2. Run the engine at idle speed until operating temperature is reached (2-3 minutes)
3. Use a screwdriver to adjust the engine idle speed to 3000 ± 200 r/min
 - Turn the idle screw clockwise to increase engine idle speed.
 - Turn the idle screw counterclockwise to decrease engine idle speed.

IMPORTANT!

Machine tubes and intake cover must be installed while adjusting engine idle! Engine idle speed will also be affected if either the intake cover or machine tubes are blocked, damaged or incorrectly installed!

STOPPING THE ENGINE

1. Cool the engine by allowing it to run at idle for 2 to 3 minutes.

2. Stop the engine by pulling the stop switch.
 - (1) Machine noise increases at higher throttle setting!
Always use the lowest throttle setting required to get the job done!
 - (2) Never operate the blower when visibility is poor.
 - (3) Always wear eye protection such as face shield or goggles while operating this machine.
 - (4) Wear a dust mask to reduce the risk of inhalation injuries.
 - (5) Wear close-fitting clothing to protect your legs and arms.
 - (6) Wear hearing protection when operating this machine.
 - (7) Never operate the blower if any component parts are damaged, loose, or missing.

1 Using the vacuum

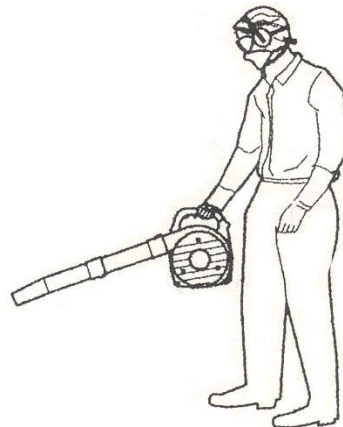
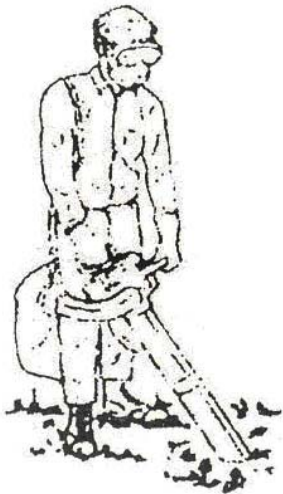

2 Using the blower

Always be aware of the strength and direction of stream.
Never direct the blower discharge stream toward people or animals.

ROUTINE MAINTENANCES

Daily maintenance



WARNING!

Before performing any maintenance on this machine, stop the engine and disconnect the spark plug wire!

Remove dirt and debris from the blower Exterior.

- Inspect the engine, tank, and hose for possible fuel leaks, and repair as necessary.
- Inspect the engine cooling fins for accumulations of dirt or debris, and clean as necessary.
- Inspect the entire machine for damage, loose or missing components or fastenings, and repair as necessary.

EVERY 10 HOURS (MORE FREQUENTLY IN DUSTY CONDITIONS)

1. Loosen the air cleaner cover retaining screw, and remove the cover and filter element.
2. Inspect the element. If the element is distorted or damaged, replace it with a new one.
3. Wash the element in clean fuel, and squeeze or blow dry. Wash the air cleaner cover in clean fuel, and wipe or blow dry.
4. Install the element and cover, and tighten the cover retaining screw.

EVERY 10/15 HOURS

1. Use the spark plug wrench to remove the spark plug (turn counter-clockwise to remove)
2. Clean and adjust the spark plug gap to 0.6-0.7mm. Replace any damaged or visibly worn plug with a champion RCJ6Y or equivalent.
3. Install the spark plug finger-tight in the cylinder head, and

then tighten it firmly with the spark plug wrench. If a torque wrench is available, torque the spark plug to 148-165 inch pounds.

EVERY 50 HOURS

More frequently if you note reduced performance

INSPECTION Inspect the entire machine and tubes for damage, including loose or missing components, and repair as necessary.

SPARK PLUG Replace the spark plug with a champion RCJ6Y, gapped to (0.6-0.7)mm.

FUEL FILTER Use a wire hook to extract the fuel filter from inside the fuel filter, and then remove and wash the filter element in clean fuel.

Before reinstalling the filter, inspect the condition of the fuel line. If damage or deterioration is noted, the vacuum should be removed from service until it can be inspected by a trained service technician.



CAUTION!

Never allow dirt or debris to enter the cylinder bore!

Before removing the spark plug. Thoroughly clean the the spark plug and cylinder head area!

Allow the engine to cool before servicing the spark plug!

Cylinder tightening or loosening the spark plug while the engine is hot!

Incorrect spark plug installation can result in serious engine damage!

STORAGE(30 days or longer)

- CLEANING** Thoroughly clean the machine exterior.
- INSPECTION** Inspect the entire machine and tubes for damage, including loose or missing components, and repair as necessary.
- FUEL** Drain the fuel tank, and then clear the carburetor and lines by running the machine until it stops from lack of fuel.
- LUBRICATION** Remove the spark plug, and then pour approximately 1/4-oz of oil into the cylinder through the spark plug hole. Before reinstalling the spark plug, pull the recoil starter 2 to 3 times to distribute the oil over the cylinder walls.
- AIR CLEANER** Remove, clean, and reinstall the filter element as described under .

TROUBLESHOOTING

1. Troubles and remedies

	Problem	Cause	Remedy
The plug does not spark	Spark plug	1. Poles wet	Dry it
		2. Covered with carbon	Clean
		3. The insulation damaged	Replace
		4. Spark gap incorrect	Adjust 0.6~0.7mm
		5. The poles burned	Replace
	Magneto	1. The wrap of wire damage	Remedy or replace
		2. Insulation of coil bad	Replace
		3. The wire of coil broken	Replace
4. The electronic firing unit defective		Replace	
The plug works well	Compression ratio and fueling well	1. Too much fuel in cylinder	Drain
		2. Water or dirt in fuel	Replace
	Fueling well but compression ratio bad	1. Cylinder and piston ring wore or tore	Replace them
		2. The plug loose	Tighten it
	Carburettor not fueling	1. No fuel in tank	fuel
		2. Filter gauze clogged	Clean
		3. The air hole of the tank clogged	Clean

2. Engine lacks power

Problem	Cause	Remedy
The compression ratio is fine	1. The filter plate clogged	Clean
	2. Air passed through the union	Tighten
	3. Air passes through the connection of carburetter	Tighten
	4. Engine overheat	Stop the engine and cool it avoid long-time heavy load and high speed
	5. Water in fuel	Refill with fresh fuel
	6. The carbon clogs muffler	Clean
Engine overheat	1. Mixed gas(fuel)thin	Adjust the carburetter.
	2. Cylinder covered with carbon	Clean
	3. Oil bad	Use 2-T engine oil and adjust the mix ration
	4. Engine not correctly running (no nozzle)	Correctly assembly the machine
Engine noisy knocking	1. Fuel bad	Replace
	2. Carbon in cylinder	Clean
	3. The running parts wore and tore.	Check and replace

3. Engine stops while running

Problem	Cause	Remedy
Engine stops suddenly	1. The lead wire of plug loose	Replace firmly
	2. Piston bitten	Change to remedy
	3. Plug covered with carbon	Clean plug
	4. Fuel used up	Fill the fuel tank
The engine stops slowly	1. Carburettor clogged	Clean
	2. The air hole in the tank clogged	Clean
	3. Water in fuel	Refill with fresh fuel

4. Dusting

Problem	Cause	Remedy
Discharge no dust or do intermitently	1. Dust gate no open	Adjust the pulling rod of dust gate
	2. Tank lid loose	Tighten
	3. The entrance of fan clogged	Clean
	4. Dust or granules mix with foreign body	Clean
	5. Dust or granules lamps	Break the lamp
	6. Dust or granules wet	Dry it
	7. Granules too big	Replace
Dust leakage	1. The sealing washer of the tank damaged	Remedy
	2. Spanner of chemical tank loose	Tighten it

(I) 1E34FBN 汽油机爆炸图
 (I) 1E34FBN GASOLINE ENGINE EXPLOSIVE PICTURE

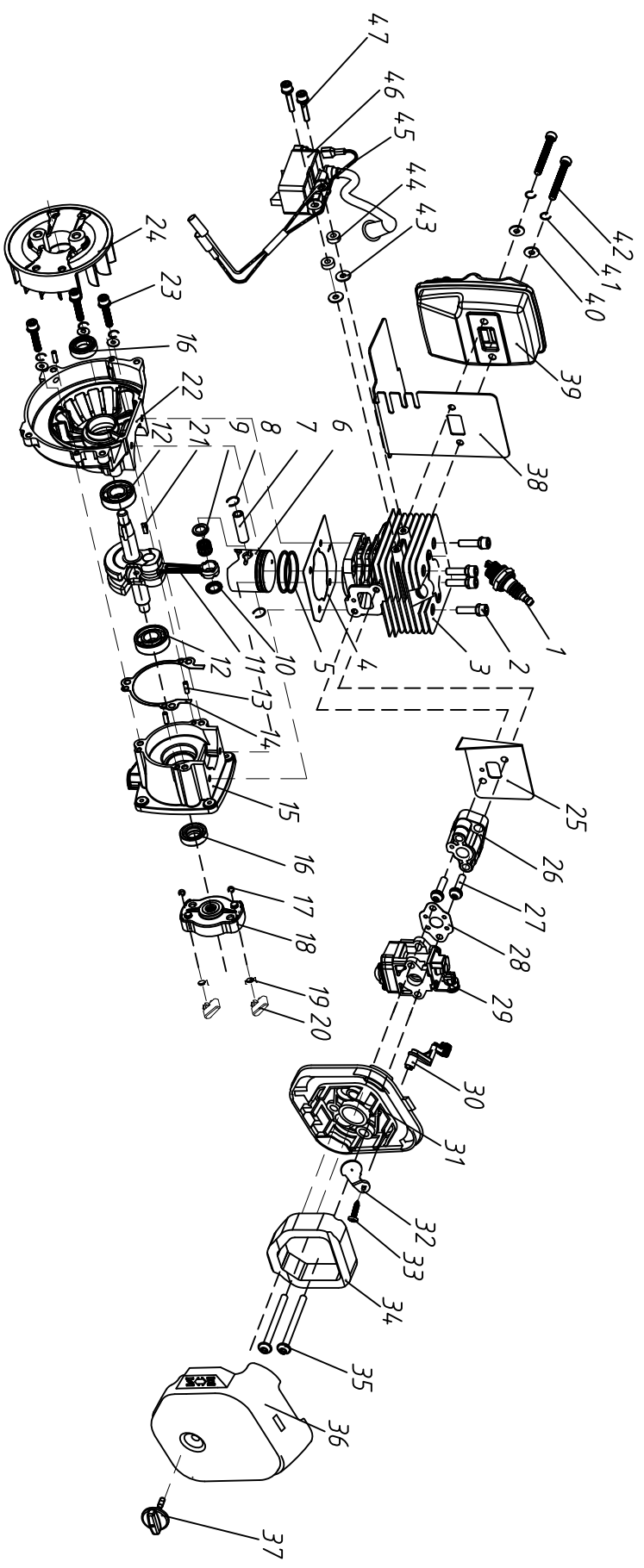

1E34FBN汽油机明细表 (I)

Appendix List Engine Parts of Attached Fig (I)

序号 Item	ERP编号 ERP NO.	零部件名称 Part Name	数量 Qty	序号 Item	ERP编号 ERP NO.	零部件名称 Part Name	数量 Qty
1	3480	火花塞 RCJ6Y Spark plug RCJ6Y	1	28	1154	化油器垫 Gasket, carburetor	1
2	5711	螺钉组合 M5X20 Bolt M5X20	4	29	1067	化油器总成 Carburetor comp	1
3	0956	缸体 Cylinder	1	30	1028	阻风门手柄 Choke Handle	1
4	7431	缸体垫 Gasket, cylinder	1	31	1355	空滤器内罩 Cleaner inside cover	1
5	0508	活塞环 Ring, piston	2	32	1339	阻风门 Choke	1
6	6457	活塞 Piston	1	33	4238	自攻螺钉 ST4×10 Bolt ST4×10	1
7	0513	活塞销 8X28 Pin, piston 8X28	1	34	0745	空滤器滤芯 Air filter element	1
8	4555	活塞销挡环 Ring, snap	2	35	4402	螺钉组合 M5X60 Bolt assy M5X60	2
9	0498	滚针轴承8*11*9 Needle bearing	1	36	0963	空滤器外罩 Cover, cleaner	1
10	3355	止推垫圈 Washer, thrust	2	37	1000	大头螺钉 Knob, cover	1
11	4653	曲轴连杆组 Crank shaft assy	1	38	0955	消音器垫 Gasket, muffler	1
12	0473	轴承 6001/P5 Bearing 6001/P5	2	39	0900	消音器(带触媒) Muffler assy	1
13	4567	定位销 B3X10 PIN B3X10	2	40	6536	平垫 5 Washer 5	4
14	7433	曲轴箱垫 Gasket, crankcase	1	41	7813	弹垫 5 Washer 5	4
15	7438	后半曲轴箱 Rear crankcase	1	42	4459	螺钉 M5×50 SCREW M5X50	2
16	0047	油封 12X22X7 Oil seal 12X22X7	2	43	4451	加大平垫 4 Washer 4	2
17	6074	挡圈GB896 Stop ring	2	44	3477	隔热垫 Space, ig coil	2
18	6468	起动拨盘 Starter pulley	1	45	0957	停车线 Stop wire	1
19	5774	启动扭簧 Starter pawl spring	2	46	0919	磁电机定子 Ignition coil comp	1
20	8575	启动抓 Starter pawl	2	47	4242	螺钉组合 M4×20 SCREW M4X20	2
21	4562	半圆键 3*3.7*12 Woodruff key	1				
22	7437	前半曲轴箱 Front crankcase	1				
23	4373	螺钉 M5X30 Bolt M5X30	3				
24	1957	磁电机转子 Rotor	1				
25	6144	进气管垫 Gasket, insulator	1				
26	0377	进气管 Insulator	1				
27	1848	螺钉组合 M5X20 Bolt assy M5X20	2				

(II) EBV260BN MACHINE EXPLOSIVE PICTURE
 (II) EBV260BN 机具爆炸图

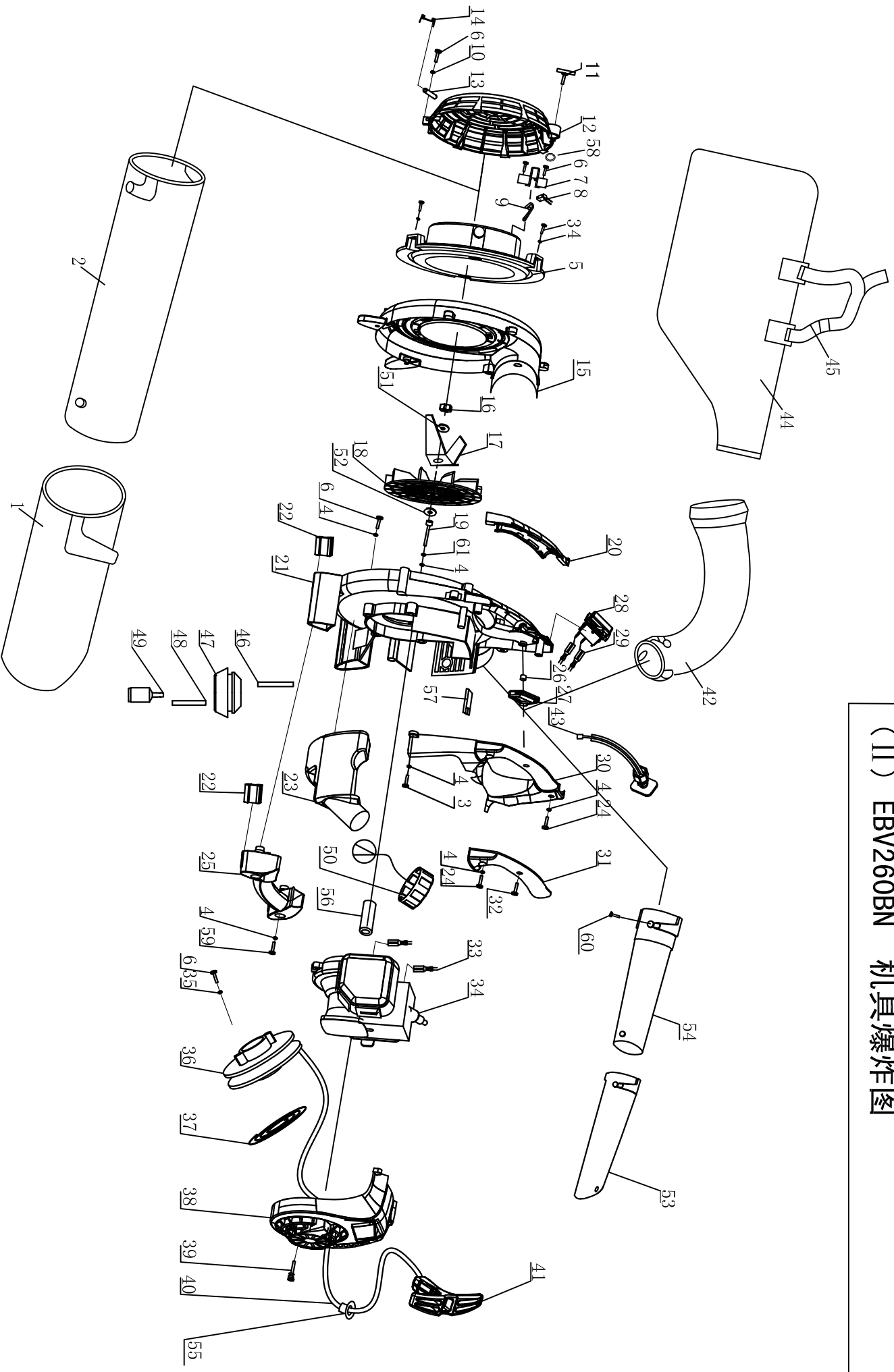

EBV260BN MACHINE PARTS LIST (II)

EBV260BN 机具明细表 (II)

序号 Ser. NO.	ERP编码 Erp NO.	名称 Part Name	数量 Qty	序号 Ser. NO.	ERP编码 Erp NO.	名称 Part Name	数量 Qty
2-1	5307	吸尘管一 INHALE PIPE NO.1	1	2-32	6622	自攻丝 4.2×10 ST4.2×10	1
2-2	5308	吸尘管二 INHALE PIPE NO.2	1	2-33	0957	停车线 STOP WIRE	1
2-3	4342	螺钉 M5×16 SCREW M5×16	14	2-34		汽油机 (1E34FBN) GASOLING ENGING(1E34FBN)	1
2-4	6536	φ5平垫 WASHER 5	24	2-35	4109	平垫 WASHER	1
2-5	5318	管接罩 CONNECT COVER	1	2-36	5349	启动绳轮 STARTER POPE REEL	1
2-6	4388	螺钉 M5×10 SCREW M5×10	6	2-37	8973	启动平簧 COLE SPRING	1
2-7	5315	连接块保护罩 CONNECTER SAFETY COVER	1	2-38	7032	防护罩 volute case	1
2-8	5299	保险开关 SAFETY SWITCH	1	2-39	4483	螺钉 M5×30 SCREW M5×30	3
2-9	5310	按钮连接块 BUTTON CONNECTER	1	2-40	3517	启动绳 STARTER POPE	1
2-10	4263	钢平垫 6 WASHER 6	1	2-41	1079	起动手柄 STARTER HANDLE	1
2-11	1000	大头螺钉 SCREW	1	2-42	5309	出尘管 TAIL PIPE	1
2-12	5313	风机网罩 FAN NET COVER	1	2-43	5296	油门绳 THROTTLE WRIE COMP	1
2-13	5282	扭簧轴 WREST SPRING SHAFT	1	2-44	5293	集叶袋 LEAVES ASSY	1
2-14	5281	扭簧 WREST SPRING	1	2-45	5294	背带组合 HARNESS ASSY	1
2-15	5312	后蜗壳 REAR COCHLEA CASS	1	2-46	8600	回油管 (L=70) RETURN FUEL PIPE(L=70)	1
2-16	4243	螺母 M8×1 NUT M8×1	1	2-47	0709	油管胶塞 FUEL PIPE RUBBER BUNG	1
2-17	4111	粉碎齿 SHATTER TOOTH	1	2-48	2718	进油管 (L=220) INLET FUEL PIPE(L=220)	1
2-18	5317	叶轮 IMPELLER	1	2-49	0554	燃油过滤器 FILTER CLEANER	1
2-19	4373	螺钉 M5×30 SCREW M5×30	4	2-50	6632	油箱盖组合 LID ASSY	1
2-20	5285	左手把胶套 LEFT HANDLE RUBBER COVER	1	2-51	4281	弹垫8 WASHER 8	1
2-21	5311	前蜗壳 FRONT COCHLEA CASE	1	2-52	7493	垫片23*8*1 WASHER 23*8*1	1
2-22	5283	底座 PEDESTAL	4	2-53	5302	出风管 A BLOW THE BREEZE TUBE A	1
2-23	5316	油箱 FUEL TANK	1	2-54	5306	出风管 B BLOW THE BREEZE TUBE B	1
2-24	3310	螺钉 M5×20 SCREW M5×20	2	2-55	5402	启动绳套 GUIDE, rope	1
2-25	5304	下手把 LOWER HANDLE	1	2-56	3785	轴套 BUSHING	1
2-26	5280	油操纵轴 THROTTLE LEVER SHAFT	1	2-57	6120	停车线胶塞 PLUG, lead wire	1
2-27	5305	油操纵手柄 THROTTLE LEVER HANDLE	1	2-58	6305	O 型圈 2.5X2 “O” SEALING WASHER	1
2-28	5292	停车开关组合 STOP SWITCH COMP	1	2-59	4237	螺钉 M5×30 SCREW M5×30	2
2-29	5295	短停车线 SHORT STOP WIRE	2	2-60	4358	螺钉组合 M5×10 SCREW M5×10	1
2-30	5303	上手把 UPPER HANGLE	1	2-61	7813	弹垫 5 WASHER 5	4
2-31	5285	右手把胶套 RIGHT HANGLE RUBBER COVER	1	2-62			



EBV260BN Blower Vac

211927



Axminster Reference No:
EBV260BN Part No: 211927

AXMINSTER
TOOL CENTRE

Axminster Devon EX13 5PH UK

FREEPHONE 0800 371822

www.axminster.co.uk

