

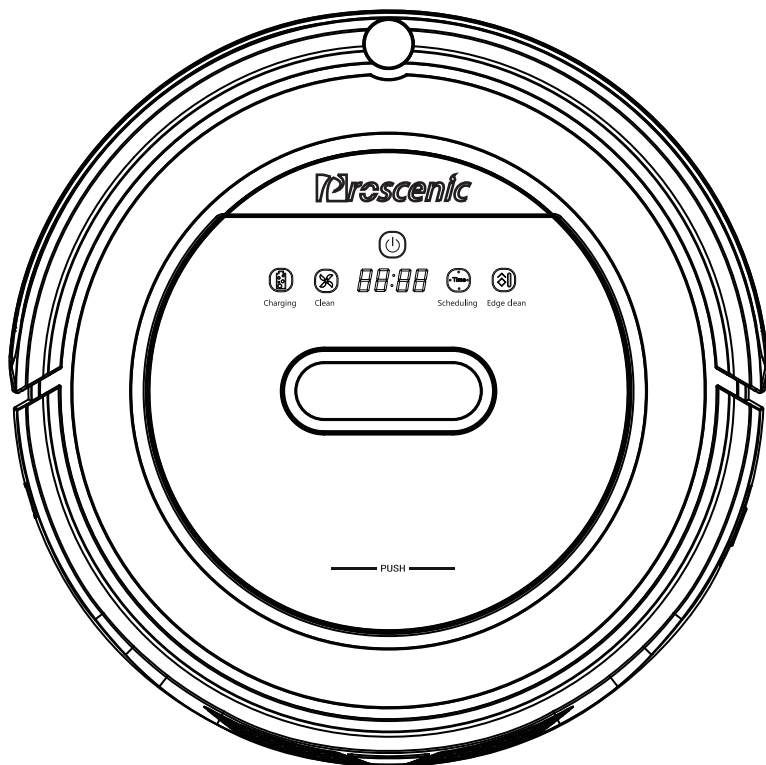

# User Manual

BL809 APPLICABLE TO SUZUKA



Please keep this user manual in your sight, read it thoroughly and carefully before using this product.

# Contents

<b>Safety Instructions</b>	<b>2-7</b>
<b>Product Features</b>	<b>8-9</b>
Humanized Designs	8
Washable Dust bin	8
Automatic Navigation	9
<b>Product Components</b>	<b>10-14</b>
Main Body and Accessories	10
Main Body Diagram	11
Dust Bin and Roller Brush Kit	12
Docking Station and Remote Control	13
Display Panel	14
<b>Product Operation</b>	<b>15-20</b>
Battery Charging	15
Power on/Standby/Sleep Mode	16
Scheduling	16-18
Cleaning Modes	18-19
Dual Modes Switching(Vacuuming and Sweeping)	20
<b>Product Maintenance</b>	<b>21-22</b>
Cleaning Side Brushes	21
Cleaning Dust Bin and Filters	21
Cleaning Sensors and Wheels	22
Cleaning Charging Poles	22
Cleaning Suction Passage and Dust Sensor	22
<b>Cleaning Roller Brush Kit</b>	<b>23</b>
<b>Product Specifications</b>	<b>24</b>
<b>Battery Replacement</b>	<b>24</b>
<b>Trouble Shooting</b>	<b>25</b>
<b>Mobile APP Quick Start</b>	<b>26</b>

# Safety Instructions

Before using this product, please read the safety instructions and follow all regular safety precautions. Warranty service is not applicable to any damage caused by violation of instructions. proscic sweeping robot is a sophisticated product which is restricted for indoor cleaning only. DO NOT use the robot for non-cleaning purpose. Please refer to user manual.

## Warning Sign



**Danger**

It indicates that any violations of instruction or improper operation are probably to cause casualties or severe injuries,



**Caution**

It indicates that any violations of instruction or improper operation are probably to cause casualties or severe injuries



**Notice**

It indicates that any violations of instruction or improper operation are probably to cause injuries to people and damage to property.

## Graphic and Sign explanation



⊘ It indicates prohibited behavior. Detailed content refer to the sign or the explanation of the sign.



● It indicates enforcement behavior. Detailed content refer to the sign or the explanation of the sign.



△ It indicates attention (including warning) content. Detailed content refer to the sign or the explanation of the sign.

\*1. Possible Severe injuries: Blindness, Burns, Electricity Injury, Fracture, Poisoning and other severe injuries that leave sequela and lead to longterm hospitalization.

\*2. Possible Injuries: Burns, and electricity wound that does not require hospitalization.

\*3. Possible Property Damage : Damage to furniture, valuable objects and injuries to pets.

# Safety Instructions

## ■ Safety Instructions of Product, Charging dock, power adapter and other accessories.

### Warning



No Disassembling

Only authorized technicians can disassemble the product. Users are not allowed to disassemble, repair or modify the product. Otherwise it may possibly cause electric shock, malfunction and leading to injuries.



Prohibited

Prohibit dismantling battery case  
Dismantling battery case may cause damage or leakage of battery that leads to fire or explosion.



Prohibited

Prohibit using metal or other conducting substance to connect battery positive and negative ends. It will lead to short circuit and cause explosion.



Prohibited

Do not use power adapter with AC inverter.  
Otherwise it may lead to over heated, malfunction or fire.



Clean Dirt

When there are dust accumulations on the metal terminals of the power plug and surrounding, be sure to clean the dust with dry cloth. Otherwise it may lead to electric shock, over temperature or fire.



Alternating Current

The adapter must use an alternating voltage from 100-240 Vac. Please plug in the socket correctly and avoid children's touch.



Prohibited

Only use the original power adapter. It may cause danger.



Prohibited

Do not destroy or modify power cord. And do not over-bend, heat, and over-pull or press the inflexible cord with heavy objects. Otherwise it will cause damage to cord and lead to fire or electric shock

# Safety Instructions



Prohibited

Never use the product under environment with volatile substance to avoid possibility of fire and danger.



Only use the product indoors.

This product is a sophisticated machine for indoor use only.



Prohibited

DO NOT leave the product to children without supervision. Otherwise it may cause injury.



Prohibited

Do not use this product under flammable or combustible environment. Use this product under propane gas, gasoline and other flammable gas, dust environment; it will lead to explosion or fire.



Prohibited

Do not wash and do not leave this product in wet or moisture environment. Do not wash main body, charging device and virtual wall. Washing or soaking will cause internal short circuit.



Prohibited

Do not sit on top of this product. Do not allow adults, children or animals to sit on this product to avoid damage to the product or falling down.



Do not touch.

To avoid stumbling, all people in the house should be noticed when this product is on. Do not touch the wheels or roller brush while product in operation to avoid being stumbled by the machine, especially children.

## Notice



Do not touch.

Do not touch the power cord, plug or adapter with wet hands. Otherwise, it may cause electric shock.

# Safety Instructions



Turn off the power

Turn off the power switch when you don't need to use this product for a long time. Battery leakage may cause fire, injury or pollution to environment. Cut off power source when using power adapter and disconnect the plug from socket. Otherwise, it may cause fire.



Prohibited

Do not have the product covered or wrapped while using.



Prohibited

This product is for indoor use only, Do not use this product to clean bathroom, warehouse, factory and bed etc.



Prohibited

**Air Outlet**

Put screwdriver or other sharp objects into air outlet will damage this product.



Prohibited

Do not wash this product.



Prohibited

Only dust bin, filters are washable.

Do not wash other parts of this product. Put dust bin, filters back to main body when dry up. Do not expose the product under the sun.

## ■ Charging Notice

### Danger



Prohibited

Use dedicated battery and charging base only. Use other batteries or docking station will cause leakage, overheating and explosion.

# Safety Instructions



No Disassembling

Unplug when not using the product to avoid short circuit. Do not disassemble the battery, otherwise, it will cause leakage, overheating and explosion.



Prohibited

Do not keep necklace, hairpin and other metal materials together with this product during transportation.



Prohibited

Do not throw the battery into fire or heat the battery.

## Attention



Prohibited

When there is overheating during charging, stop using this product immediately.



To extend battery's life, take out the battery and put it in cool and dry place when not using it,



Do not immerse or wash this product



Do not use this product when there is signs of unusual (change of color or shape).



The battery must be insulated with tapes when recycling or disposal. Contact with other metal will lead to heating, burst or fire. Bring the used battery to technical service center or recycler with authorized reseller for disposal. Or dispose the battery according to local laws.

# Safety Instructions

## Warning



Prohibited

Do not keep necklace, hairpin and other metal materials together with this product during transportation.



Prohibited

Do not charge this battery on other devices  
This chargeable battery is designed for this smart robot only.



Prohibited

Do not put the battery back to main body or charge it when deformation, swelling and electrolyte leakage are found from battery case.



Prohibited

Wash off the battery leakage immediately with clean water when there is contact with skin or clothes.No measures taken will lead to skin inflammation.Do not crash or throw the battery.

It's not allowed to copy, publish or record this user manual and related material in any searchable media or translate to any other languages without our written authorization.

We have made our best efforts to make sure the precision and completeness of this user manual. Any mistakes or omission are found, we sincerely thank you for giving us feedback through our feedback email [feedback@proscenic.tw](mailto:feedback@proscenic.tw)



# Product Features

This is an outstanding and extraordinary automatic cleaning robot which is well equipped with not only cleaning function, double side brushes, strong vacuuming suction, but also with interchangeable roller brush kit and vacuum suction kit

## Intelligent Suction Adjustment

This product is able to automatically adjust its suction power when different floor environments are detected. This ability not only makes cleaning more efficient, but also helps to save more power (up to 30%)

## User Friendly Design

Operation is simple and easy.

Start the robot by touch  button.

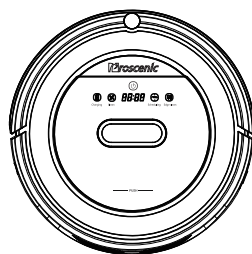

## Washable Dust bin

Dust bin and filters can be washed by water. Simply wash dust bin under water after use to avoid dust blowing in the air to cause a second pollution !

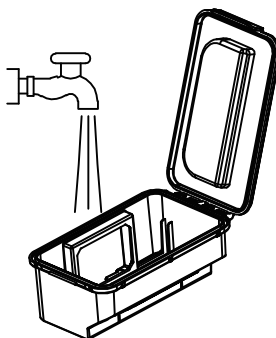



# Product Components

## Main Body and Accessories

NO.	Description	Quantity
1	Main Body	1
2	Docking Station	1
3	Adapter	1
4	Remote Control (battery not included)	1
5	HEPA Filter	1
6	Side Brush	4
7	User Manual	1
8		
9		
10		

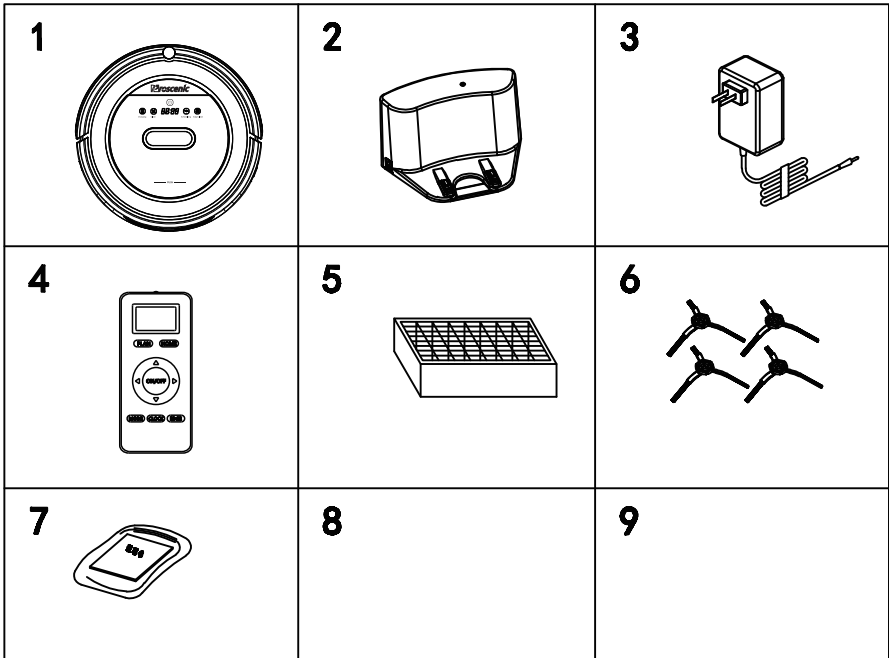

# Product Components

## Main Body Diagram

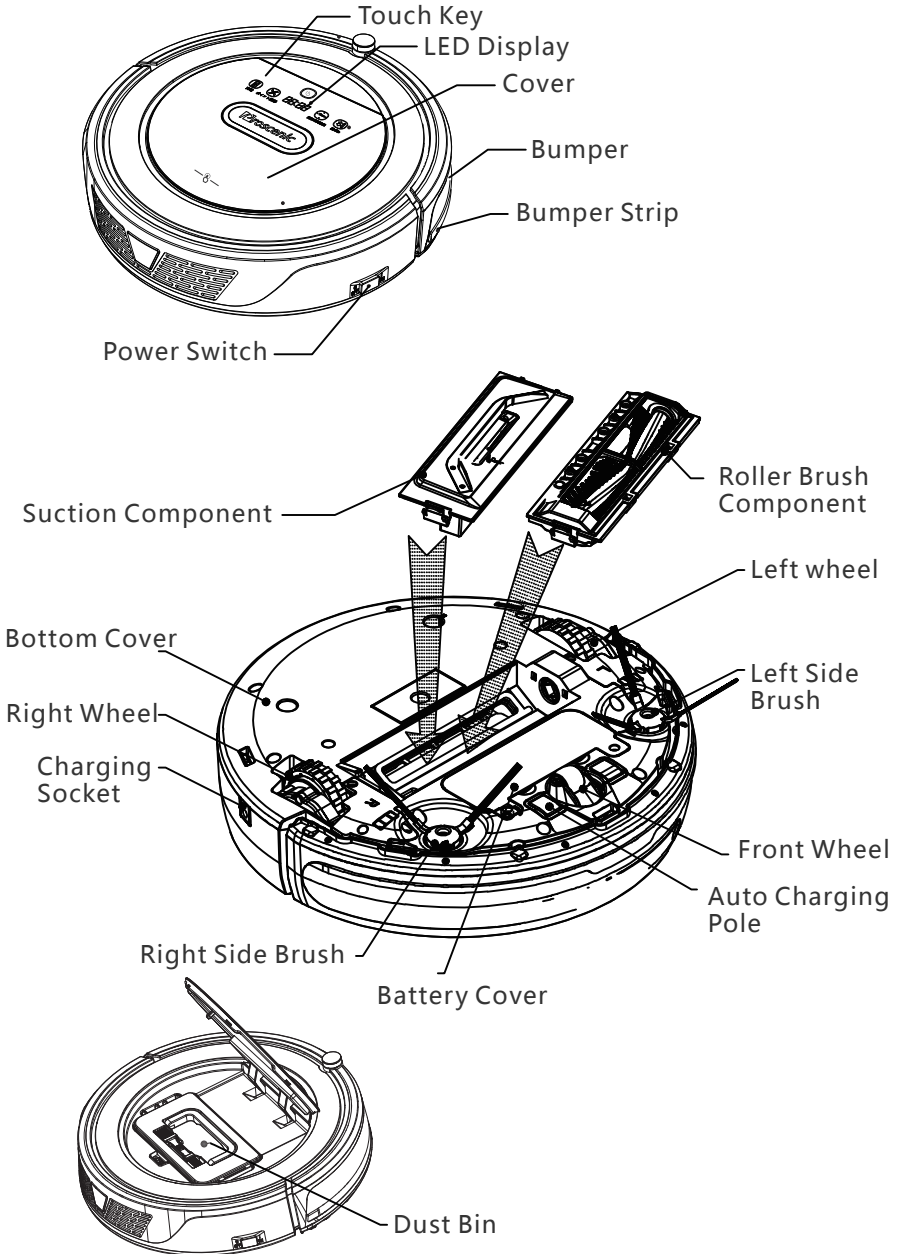

# Product Components

## Dust Bin Kit

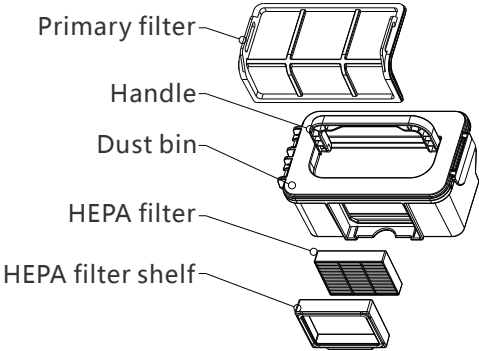

## Roller Brush Kit

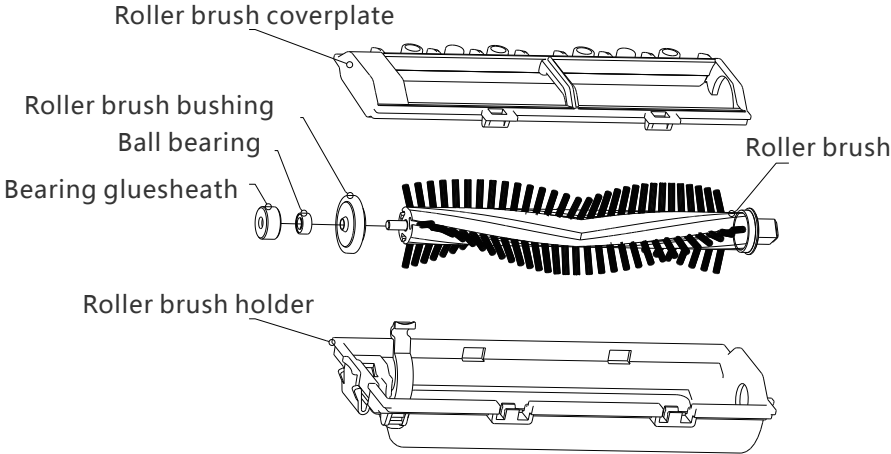

# Product Components

## Docking Station

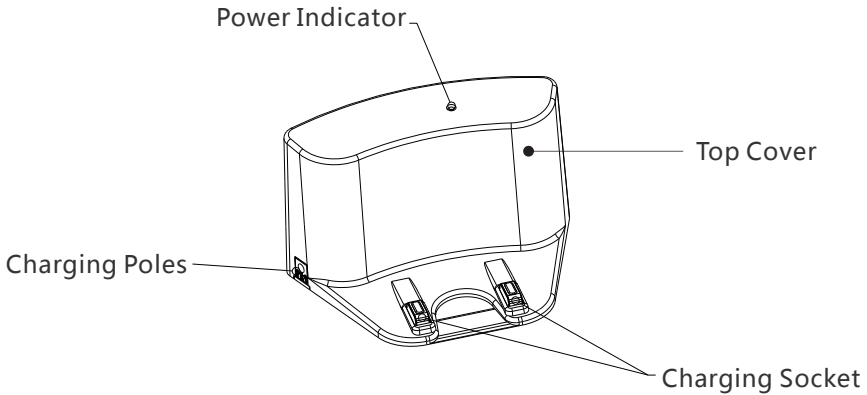

## Remote

1. Display Screen
2. Auto Charging
3. Direction Button  
(Only Effective in Standby Mode)
4. Edge Cleaning  
(Only Effective in Standby Mode)
5. Clock Setting
6. Schedule Setting
7. ON/OFF
8. Area Cleaning  
(Only Effective in Standby Mode)

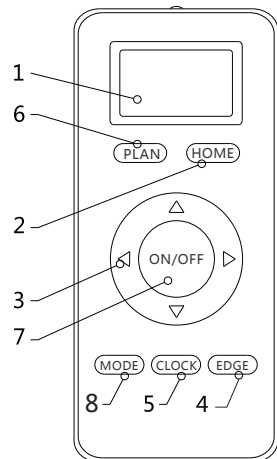

### Note:

Install two AAA type batteries into the remote control before use, Remove the batteries if the remote control will be left unused for a long period.

# Product Components

## Display Panel

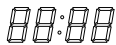
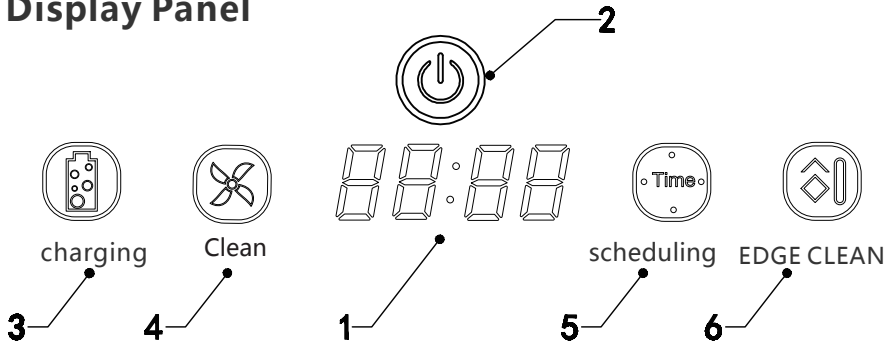

panel

it shows the time setting, charging status, and error codes by using numbers

## Button



- A. Press this button to activate from sleep mode to standby mode.  
In standby mode, press this button and hold it for more than 3 seconds to go into sleep mode.
- B. Confirm schedule setting in scheduling mode.
- C. Start cleaning in standby mode.



- A. Press this button to increase number in scheduling mode.
- B. In other mode, press this button to start auto-homing and charging mode.



- A: Press this button to decrease number in scheduling mode.
- B: In other mode, press this button to start auto cleaning.



- In standby/charging mode, press this button to enter/quit robot time setting.
- Hold this button to enter/quit scheduling mode.



- Press this button to start edge cleaning in standby mode.

# Product Operation

## Battery Charging

### 1. Docking station placement

Place docking station against the wall and remove obstacles from within 1 meter at two sides and about 2 meters in front of the station, as shown in the right figure.

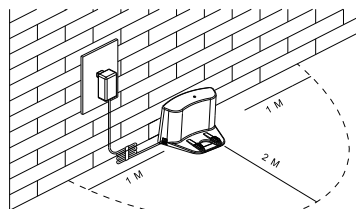

If the robot has been shut down, power on the robot by pressing the power switch. side of the robot for more than 3 seconds.

### 2. Charge the robot in either way as shown below:

a. Insert the adapter into the robot and the plug at the other end to the power socket as shown in Figure.a.

b. Press  on robot or HOME on remote control to operate the robot to go back to the charging station for recharging as shown in Figure.b.

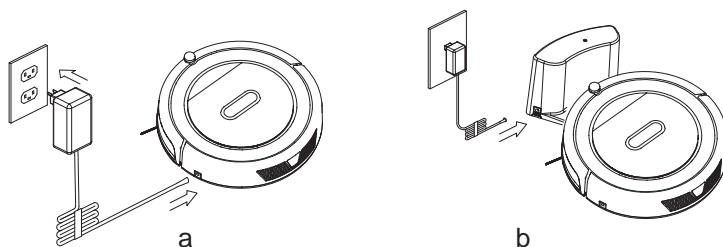

### Note:

- When robot is being charged, LED panel will gradually show 1111 from left to right.
- Once charging is complete, LED panel will show FULL.
- In the standby status, the robot will broadcast voice prompt 'Please charge' when battery power is low.
- In the working status, the robot will return to charging station automatically when battery power is low.

### For extending battery life:

- Before first use, charge the robot for 12 hours.
- Charge the robot as soon as possible when battery power is low.
- The robot will return to charging station automatically when it completes cleaning or battery power is low.
- If the robot is not to be used for a long time, fully charge the battery before use and turn the power switch off.
- If the robot is not to be used for more than 3 months, charge the robot for 12 hours.





# Product Operation

## Starting Up / Standby / Sleeping / Power Off

### 1. Starting up

- a. Make sure the power switch is on(The power switch is at the right side of main body)
- b. In standby mode, press  on main body or ON/OFF on remote control to start cleaning.

**Note:**

If robot is in sleep mode, press  on main body to wake up the robot from sleep mode, then press  again, the robot will start cleaning automatically.

### 2. Standby

Standby means robot has its power switch on, waiting for the user's operation. It can be changed to standby mode by one of the following methods:

- a. During robot cleaning, press  on main body to enter standby mode.
- b. During robot cleaning, press ON/OFF button on remote control to power off the robot.

### 3. Sleep

In sleep mode, the robot can only be waken up from  button on main body or ON/OFF on remote control. In order to save power, you can turn the robot into sleep mode from standby mode via either of the following methods:

- a. Press  on main body and hold it for 3 seconds.
- b. Robot will automatically enter sleep mode if no command is received for more than 2 minutes



## How to schedule the robot

### 1. Schedule on Display Panel on Main Body



#### A. Setting robot clock (Make sure the robot is in standby or power on status)

- a. Press "Schedule" button to start clock-setting. the LED panel will show the current system time.
- b. Then the left two numbers on LED panel will flash .Press "Home" to increase hour or clean to decrease it.

# Product Operation

- c. Press  to enter minute-setting mode, the right two numbers on LED panel will flash. Press  to increase it or “Clean” to decrease it.
- d. Press  button to save the setting, then press “schedule” to exit (Before the setting is saved, if press “Schedule” to exit, the current setting will be invalid).

## B. Setting the scheduling time (Make sure the robot is in standby or power on status)

- a. Press “schedule” and hold it for 3 seconds to start scheduling, then the left two numbers on LED panel will flash.
- b. Press “Home” button to increase hour or “Clean” button to decrease it.
- c. Press  to enter minute-setting mode, the right two numbers on LED panel will flash, press “Home” button to increase it or “Clean” button to decrease it.
- d. Press  again to save the setting, then press “Schedule” button to exit (Before the setting is saved, if press “Schedule” to exit, the current setting will be invalid).

## C. Cancel the scheduling

Set the scheduling time to 00:00.

### **Note:**

- a. Before scheduling, please set the robot time to be the same with real time.
- b. The robot will start cleaning at the schedule time of Robot Clock every day. Schedule has to be reset again after the power switch has been turned off.

## **2. Schedule on Remote Control**

### A. Scheduling Setting

- a. Make sure the robot is in standby or charging status. Press “Schedule” button on remote and hold it for 3 seconds to enter scheduling mode.
- b. Then numbers on LED screen on the remote will flash. Change flashing numbers by pressing “Up” or “Down” button. Press “Left/Right” button to set next digit when finishing the setting of previous digit.
- c. When finish setting, with the remote pointing to the robot, press “ON/OFF” button on remote. Display panel will show corresponding time when it's been scheduled successfully.



# Product Operation

- b. Choose area cleaning "mode 2" , the screen on remote will show "MODE 2" and the robot will clean about 2\*2m square area line by line.
- c. Choose area cleaning "mode 3" , the screen on remote will show "MODE 3" and the robot will clean about 3\*3m square area line by line.
- d. Choose area cleaning "mode 4" , the screen on remote will show "MODE 4" and the robot will clean about 4\*4m square area line by line.

The robot will all return to its start point when above cleaning modes completed.

## 3. Edge cleaning

In cleaning mode, press  to enter edge cleaning mode. The robot will clean along the walls.

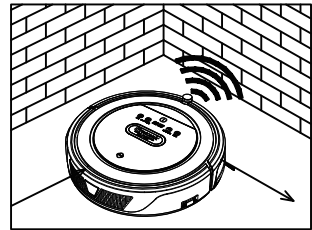

## 4. Schedule cleaning

Schedule the robot's cleaning according to your need. And our robot will start cleaning as scheduled.

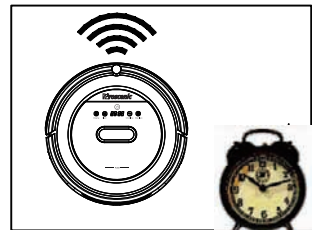

# Product Operation

## Vacuumping and Sweeping Switching

(Applicable to certain models, consult your customer service)  
The suction kit and the roller brush kit are replaceable. You can install accordingly as below as your need

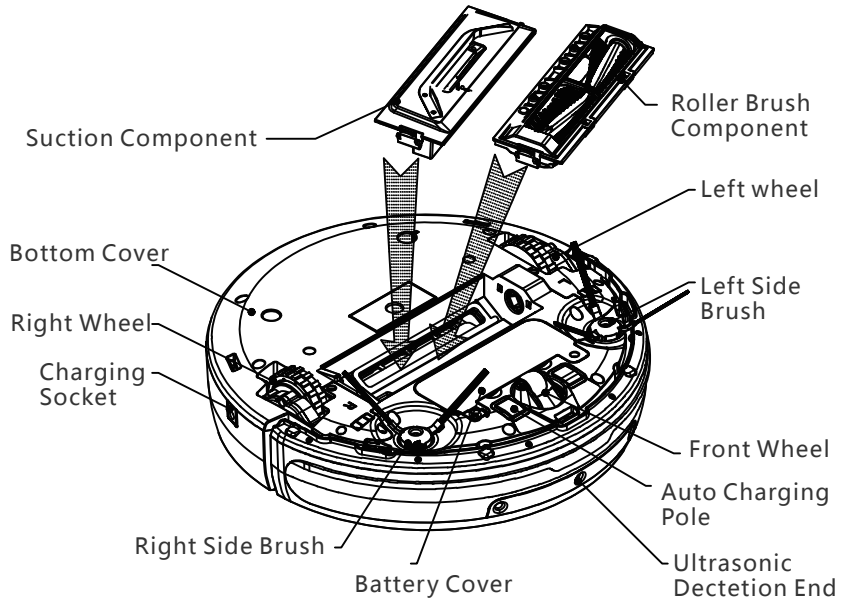

# Product Maintenance

## Cleaning Side Brushes

1. Make sure side brushes are not damaged and no foreign matter among them.
2. Use cleaning kit or cloth to clean side brushes.
3. Remove side brushes and put them in warm water for five seconds can solve side brushes tangling and deformation.
4. Replace side brushes when they are worn.

## Cleaning Dust Bin and Filters

Empty and clean the dust bin after each use following the steps as shown in the figures below.

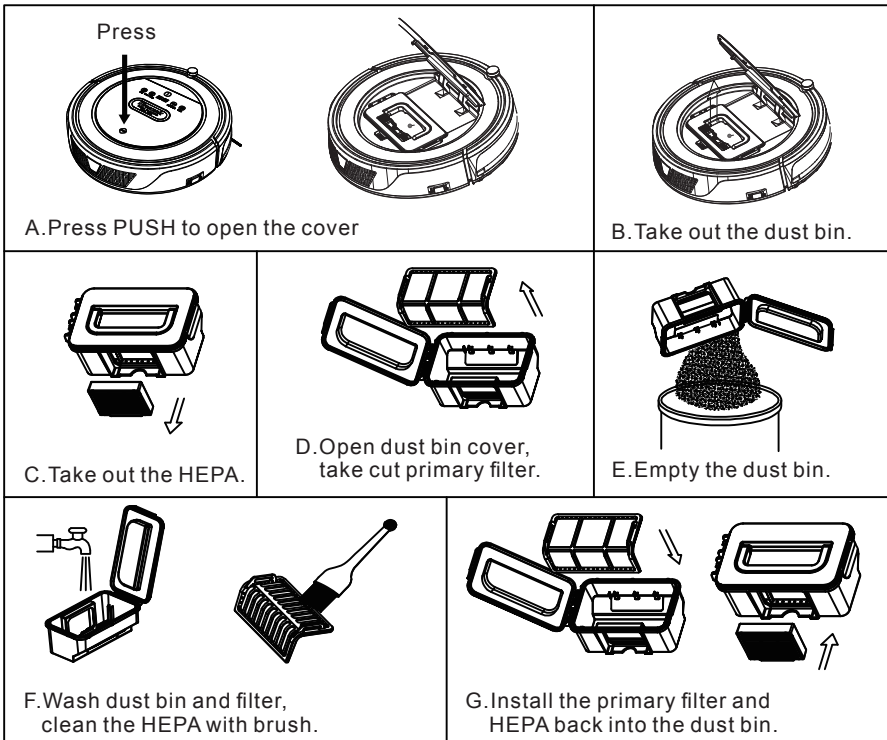

### Note:

- a. Wash the HEPA and primary filter after used for 15~30 days. Max life span for HEPA and primary filter is 24 months.
- b. Reinstall the HEPA and primary filter after they are fully dry.
- c. HEPA and primary filter could be replaced if needed.
- d. Do not dry the filters under baking sunshine.

# Cleaning Sensors and Wheels

Slightly wipe all the sensors and wheels, as marked in figure below, with soft cleaning cloth or tool.

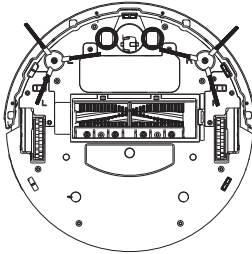

# Cleaning Charging Poles

Clean the charging poles, as marked in figure below, with soft cleaning cloth or tool.



Clean the charging poles with soft dry cloth when there is bad contact.

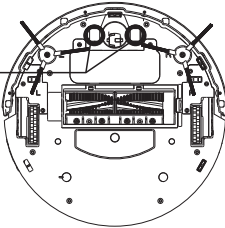

Clean the charging poles with soft dry cloth when there is bad contact.

# Cleaning Suction Passage and Spot Cleaning Sensors

Remove suction passage kit from main body. Clean the suction passage and dust sensors, as marked in figure below, with soft cleaning cloth or tool.

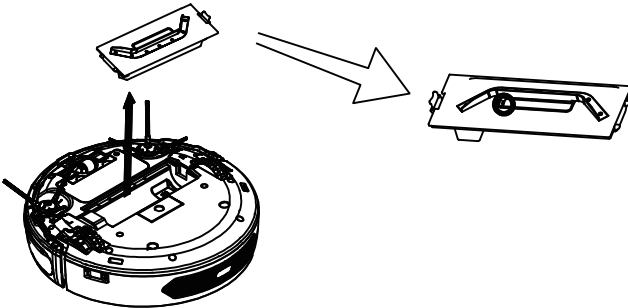

**Note:** Avoid allowing the sensors to get wet by water, thinner, etc.

# Product Maintenance Kit

## Cleaning Roller Brush

Take out and disassemble the roller brush kit as shown in figure below, and clean it with soft cleaning cloth or tool. (The roller brush axle is washable)

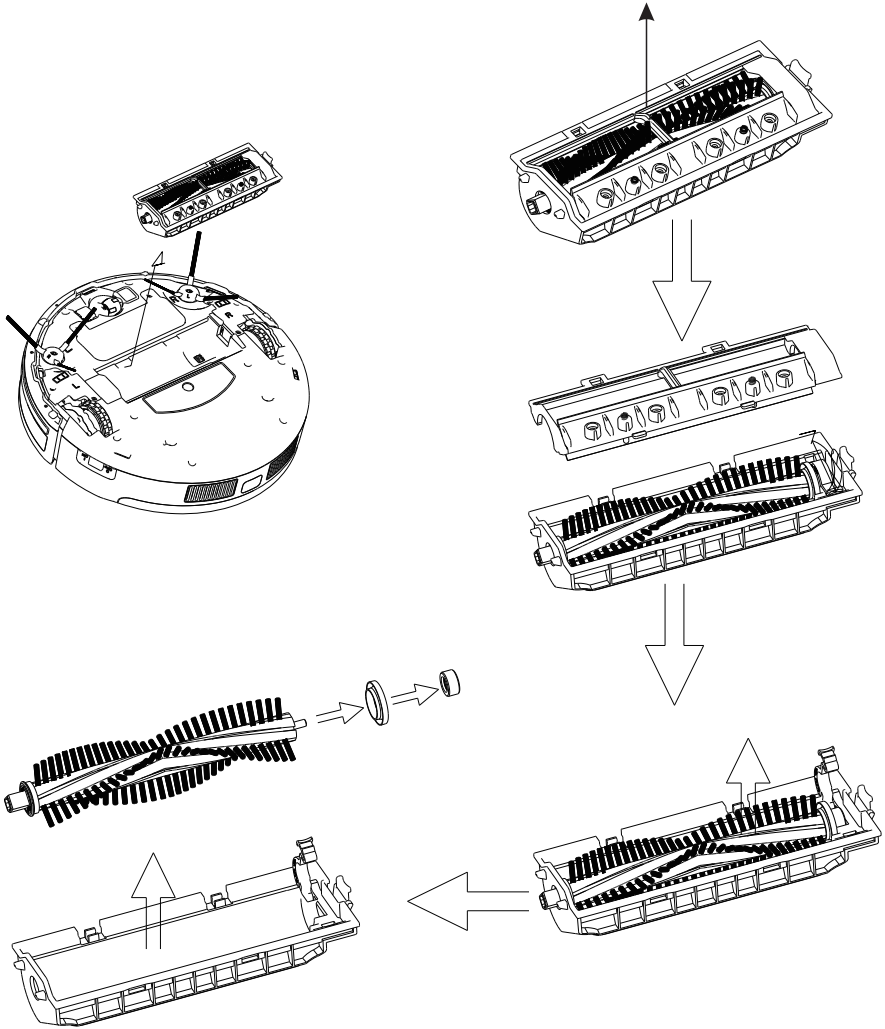

**Note:** Please re-install the roller brush axle after it is fully dry.



# Product Specifications

## Product Specifications

Classification	Item	Detail
Mechanical Specifications	Diameter	350mm
	Height	99mm
	Weight	3.7Kg
Electrical Specifications	Power Rating	14.4V
Cleaning Specifications	Charging Type	Auto Charging/ Manual Charging
	Cleaning Mode	Auto, Area, Edge, Schedule
	Charging Time	4~6 hours
	Cleaning Time	100 mins
Main Body Button Type		Touch pad (LED display)

## Battery Removal

- 1.Unscrew the screws on battery cover with a screw driver
- 2.Remove the battery capsule cover
- 3.Take out the battery
- 4.Push the electrode tips connected the battery and main body.
- 5.Put the new battery into the battery case with the battery label facing up
- 6.Plug the wire connector that connects the battery and robot.
- 7.Reorganize the wire connector and wires.
- 8.Reinstall the battery door
- 9.Lock the battery capsule cover

**Notice:** Do not use non original battery. It may cause damage to the robot.

# Troubleshooting

## Error Code

Number	Error code	Cause
1	E1	Dust bin not well located or robot without dust bin
2	E2	Power switch off during charging
3	E3	Low voltage power supply or auto charging failure
4	E11	Left anti-drop sensor detect cliff
5	E12	Right anti-drop sensor detect cliff
6	E13	Front anti-drop sensor detect cliff
7	E21	Left wheel drop
8	E22	Right wheel drop
9	E31	Front bumper wall detection sensors and left infrared sensors detect obstacle
10	E32	Front bumper wall detection sensors, right infrared
11	E33	Front bumper wall detection sensors and front infrared
12	E41	Left wheel overloaded
13	E42	Right wheel overloaded
14	E43	Left side brush overloaded
15	E44	Right side brush overloaded
16	E45	Right wheel overloaded
17	E46	Roller brush overloaded
18	L0	Low battery
19	11:11	Charging
20	FULL	Charging Completed

### Notice:

If above solution does not work, please try below:

- a. Reset the robot by switching off the unit and then turn it on, and check again.
- b. If it still does not work after reset, contact after sales support service@proscenic.tv

# Mobile APP Quick Start

Proscenic Mobile APP is available on iOS and Android.



1. Go to Apple App Store (iOS) or Google Play (Android), search "Proscenic" , download and install.
2. Run the app and signup an account for the first time.
3. Please make sure your phone is connected to current WIFI.
4. Hold " charging " button on the robot until you hear a Chime.
5. Robot should have "CONN" displayed, and Click the "Search robot" button.
6. Enjoy your app.