

FREESTANDING PELLET STOVE

P6, P9 and P12

ORIGINAL OPERATING INSTRUCTIONS

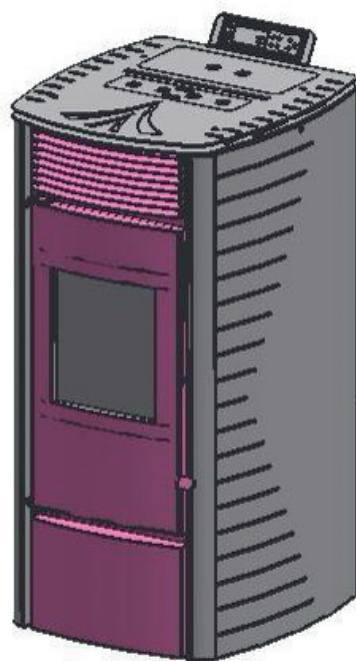
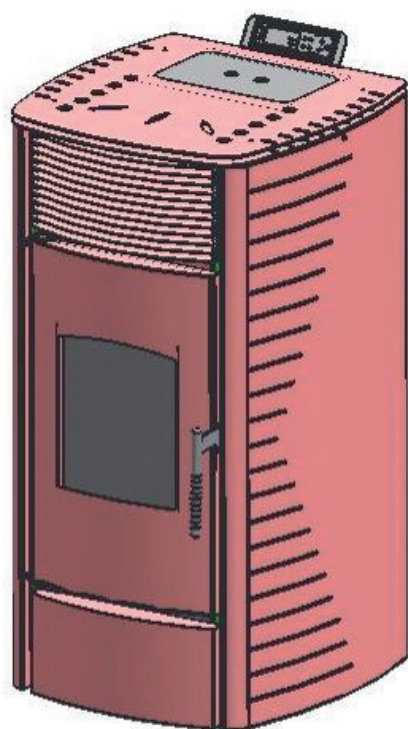

TABLE OF CONTENTS

1. Fuel Requirement	3
2. Stove Features.....	4
3. Method of construction	5
4. Pellet Stove Installation	7
5. Operation	11
6. Cleaning and Maintenance	26
7. Troubleshooting	30
8. Electronic Plan	35
Declaration of performance and test report	37



IMPORTANT:

- Please read this entire manual before installation and use of this pellet fuel burning room heater.
- Failure to follow these instructions could result in property damage, bodily injury, or even death.
 - Save these instructions!

INSTALLER: THIS MANUAL MUST STAY WITH APPLIANCE!

1. FUEL REQUIREMENT

Pellets are made from wooden waste, from sawmills and planning workshops, as well as from residue from forestry operations.

These “starting products” are crushed, dried, and pressed into Pellet “Fuel” without any bonding agent.

SPECIFICATIONS FOR HIGH QUALITY PELLETS

Calorific Value: 5.3 kWh/kg

Density: 700 kg/m³

Water Content: Max. 8% of the weight

Ash proportion: Max. 1% of the weight Diameter: 5 - 6.5mm

Length: Max. 30mm

Contents: 100% wood untreated and without any bonding agents added
(bark proportion max. 5%)

Packaging: In sacks, made of environmentally neutral or biologically degradable plastic,
or from paper (2-3 layers / similar to cement packaging)



Please ask your pellet stove dealer for tested fuel and a list of monitored fuel manufacturers.

Using poor quality or prohibited pellet fuel will have a negative effect on the function of your pellet stove and can also lead to the warranty becoming null and void, as well as the product liability connected with this.

Observe waste incineration legislation.

Burn only pellets that have been tested.

PELLET STORAGE

In order to guarantee problem free burning of the wooden pellets, it is necessary to store the fuel as dry as possible and free from impurities.



This appliance is not intended for use by persons (including children) with reduced physical, sensory or mental capabilities, or lack of experience and knowledge, unless they have been given supervision or instruction concerning use of the appliance by a person responsible for their safety:

Children should be supervised to ensure that they do not play with the appliance.

2. STOVE FEATURES

Pellet stove is advanced designed and has individual fresh air input and venting system. Negative pressure burning technology causes high efficiency and little ash outlet during burning. It will be shut off automatically by wrong burning or lack of fuel. Large BTU, quick heating and low fuel cost are its advantages.

1. Main performance

Modell		P12	P9	P6
Dimension (WxHxD)	MM	543 x 1072 x 593	463 x 971 x 549	463 x 771 x 549
Weight NET/GROSS	KG	110 / 130	95 / 110	85 / 100
Air inlet Pipe	MM	50	50	50
Air outlet Pipe	MM	80	80	80
Heating Performance range	KW	3.8-11.5	3-9	3-6
Room heating capacity (m ³) dependent on house insulation	M ³	60-300	60-220	60-120
Consumption for Pellet (Min-Max)	KG/H	0.6-2.5	0.5-1.75	0.4-1.15
Pellet container capacity	KG	28	14	7,5
Automatic Burning Time (Min-Max.)	H	17-37	10.5-36	13-37
Power supply	V / HZ	230 / 50	230 / 50	230 / 50
Average Electrical consumption	W/H	80	80	80
Fuse	A	3	3	3
Efficiency	%	90%	88%	88%
CO ₂ content	%	9.8%	8%	7.8%
CO emission re. 13% O ₂	Mg / NM ³	74	84	85
Dust emissions	Mg / NM ³	22	18	20
Exhaust air mass flow	g/s	7.6 / 4.9	7.1 / 4.3	5.6 / 4.4
Exhaust air temperature	°C	178 / 92	169 / 112	158 / 113
Chimney draft requirement	Pa	12 / 10	12 / 10	12 / 10

3. STRUCTURE INSTRUCTION

The stove is mainly made up of following items:

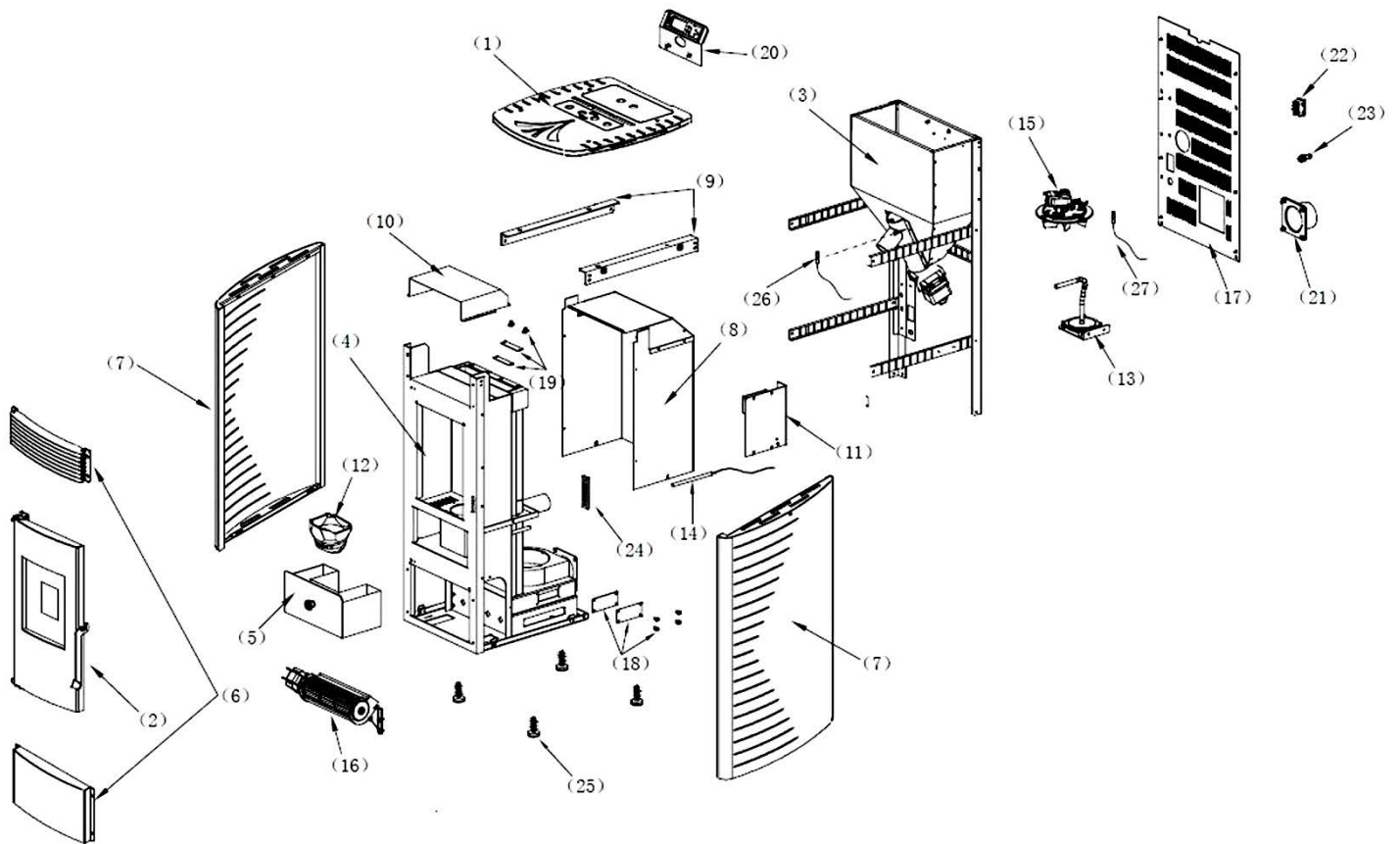

- | | | |
|-------------------------------|------------------------|--|
| 1. Top covers | 11. Motherboard | 21. Exhaust connection |
| 2. Door | 12. Fire pot | 22. Power input socket
(contains the main fuse) |
| 3. Pellet Hopper | 13. Vacuum Switch | 23. Room temperature sensor |
| 4. Pellet Chamber | 14. Igniter | 24. Handle |
| 5. Ash Drawer | 15. Combustion fan | 25. Stove Feet |
| 6. Front Top and bottom cover | 16. Blower | 26. Safety temperature sensor |
| 7. Side Panels | 17. Rear Cover | 27. Exhaust temperature
sensor |
| 8. Chamber Insulation cover | 18. Bottom Clear cover | |
| 9. Shoulder | 19. Top clear covers | |
| 10. Hot wind driver | 20. Display | |

The heater is mainly made up of following items:

1. Combustion burn pot
2. Exhaust fan
3. Room circulation fan and auger motor.

The following is a list of main components and their functions:

IGNITER

The HEATER comes equipped with an automatic electric igniter for lighting the fuel when the heater is in lighting mode only.

The igniter remains energized for the first eight minutes of the lighting sequence.

VACCUM SWITCH

The HEATER has a safety vacuum switch located behind the left door, fastened to the base.

If a low pressure is created in the firebox by a leak, opening the front door, a blocked flue, or unsealed ash drawer, the vacuum switch will sense it and cause the heater to go into a shutdown mode.

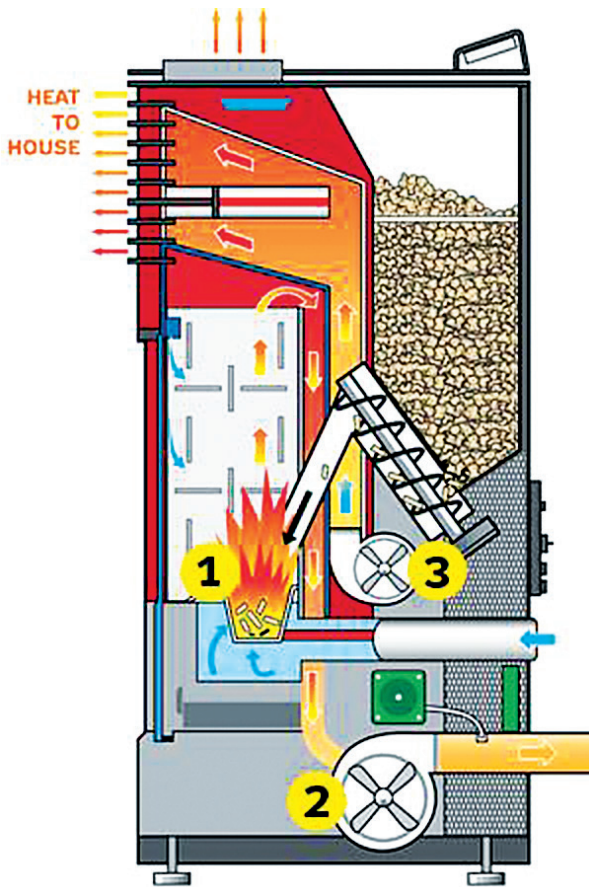

AUGER AND AUGER MOTOR

The 2 RPM auger motor turns the auger lifting pellets up the auger tube.

The pellets end down a tube and into the firepot. The auger is controlled by the control board.

OVER TEMPERATURE THERMOSTAT

This safety switch is installed on the bottom of hopper and will shut off the heater if it senses excessive temperatures (70 degrees).

CONVECTION BLOWER THERMOSTAT

This switch is installed on the vent pipe and turns the convection blower on when the heater is above 40 degrees.

4. PELLET STOVE INSTALLATION



All NATIONAL AND LOCAL REGULATIONS AND EUROPEAN STANDARDS SHALL BE COMPLIED WITH WHEN INSTALLING THE APPLIANCE

Before installing a stove in a room, select the right stove to be able to heat the room.

Please check the STOVES' Heating area in the Chapter of STOVE FEATURES.



ASSEMBLE THE STOVE BEFORE INSTALLATION

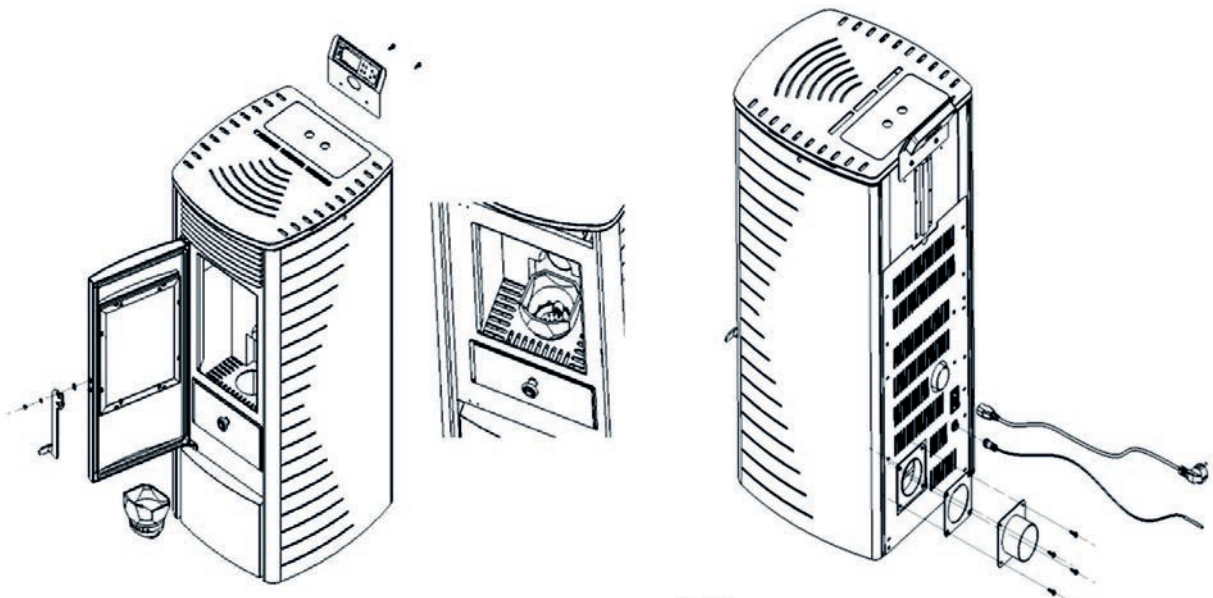

GENERAL INFORMATION

The stove must be connected to a chimney that is approved for solid fuels. The chimney must have a diameter of at least 80 mm.

The flue system is based on negative pressure in the combustion chamber and a slight overpressure on the flue gas outlet. It is therefore important that the flue gas connection is fitted correctly and is airtight.



Only use heat resistant sealing materials, as well as the relevant sealing bands, heat resistant silicon and mineral wool.

Only authorized technical personnel must carry out assembly work.

In addition you must ensure that the flue tube does not project into the free cross section of the chimney.



NOTE: Please follow the regionally valid building regulations. Contact your master chimney sweep for information regarding this.

Ensure that outlet routes to the chimney are not too long.

Avoid too many changes of direction for the flue gas flow to the chimney (e.g. too many corners and bends).

If you cannot connect directly to the chimney, use a connection piece with cleaning opening if possible.

For optimum efficiency please use the type of connector we recommend.

MAKING THE CHIMNEY CONNECTION

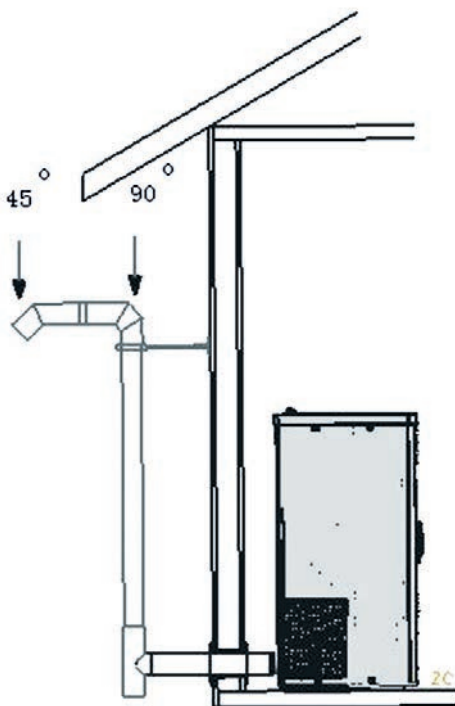

Horizontal

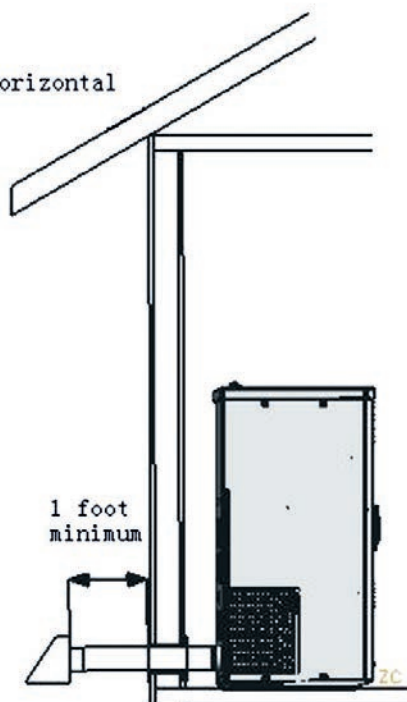

Horizontal

(This is not recommended, when the electronic power is off, the smoke might come out if the stove is on)

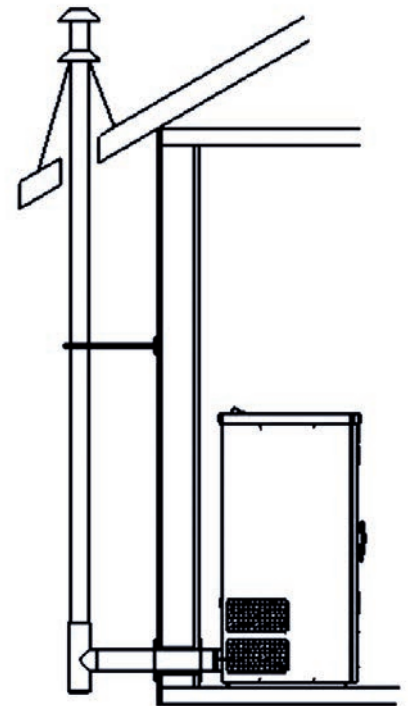

Horizontal and up through the eave.

Method

1. Measure and draw the chimney connection (taking any floor plate thickness into consideration).
2. Chisel out (drill) the hole in the wall
3. Brick in the wall lining
4. Connect stove with the flue tube to the chimney.

FLOOR PROTECTION

For flammable floor surfaces (wood, carpet, etc.) a glass, steel plate or ceramic underlay is required.

SAFETY DISTANCES (measured from the outside of the stove)

From non-combustible objects

A > 400 mm, B > 100 mm, C > 100 mm

From combustible objects and to load-bearing walls in reinforced concrete

A > 800 mm, B > 200 mm, C > 200 mm

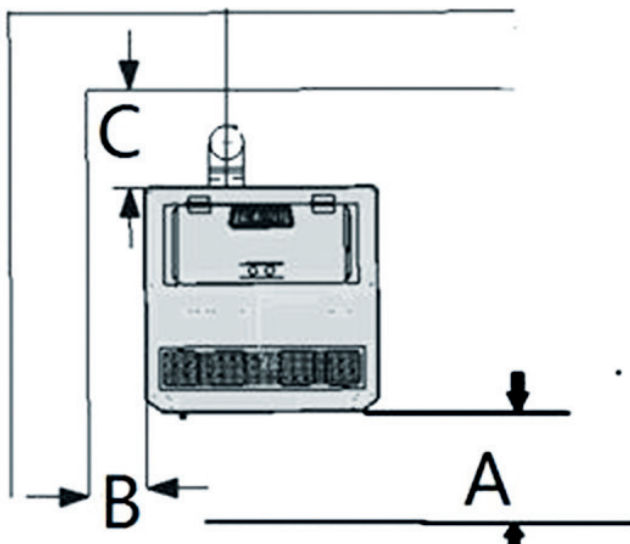

ELECTRICAL CONNECTION

The stove is supplied with an approx. 2 m long connecting cable with a plug. The cable must be connected to a 230 V, 50 Hz electrical supply.

The average electric power consumption is approx. 100 watts during heating.

During the automatic ignition process (duration 10 minutes) approx. 350 watts.

The connection cable must be laid so that any contact with hot or sharp-edged external surfaces on the stove is avoided.

COMBUSTION AIR

Each combustion procedure requires oxygen or air. As a rule this combustion air is removed from the living area for individual stoves. The air taken from the living area must be reintroduced. In modern houses, very tight fitting windows and doors can cause that not enough air flows back. This situation becomes problematic due to additional ventilation in the house (e.g. in the kitchen or WC).

The suctioning in of combustion air is performed via the flue gas blower. The resulting combustion air and suctioning noises are normal operational noises that may occur at varying volumes depending on the chimney draught, output level or a dirty combustion trough – NOT A CAUSE FOR COMPLAINT!

Feed of external combustion air

- Steel, HT or flexible aluminum pipes must be used.
- Minimum diameter 5 cm/2 inches.
- For longer connection runs the diameter must be increased to approx. 10 cm after approx. 1 m.
- The pipe should not be longer than approx. 4m in total to guarantee adequate air feed and not have too many bends.
- Should the line lead into the open air, it must end with a vertical 90° downward elbow or with a wind guard. Should one or more of these conditions NOT be applicable then usually poor combustion will occur in the stove, as well as air under pressure in the apartment.

We recommend that a ventilating grille be fitted in a window near the stove for permanent ventilation. Further it is possible to extract the combustion air directly from outside or from another room that is well ventilated (e.g. the cellar).

Please observe:

Your pellet stove works independently of the room air. Negative pressures in the set-up room are not permissible. Therefore the use of a safety device (e.g. differential pressure controller) in combination with room air facilities (e.g. ventilation system, exhaust extraction etc.) is stipulated.

5. OPERATION



ALL NATIONAL AND LOCAL REGULATIONS AND EUROPEAN STANDARDS SHALL BE COMPLIED WITH WHEN OPERATING THE APPLIANCE

ATTENTION: When the stove is in operation, please don't touch the front. It is extremely hot!



NOTE:

During first time running, the paint may burn. This may cause unpleasant smell. Please open the window and door for ventilation.



NOTE:

Before first usage it is necessary to put a handful of wood pellet to the fire pot.



NOTE:

The fire pot and underneath the fire pot must be clean every time you start the stove!

Put wood pellet fuel into the hopper, connect the power. Then On/Off Light is lit (It means that power is on).

Follow instructions in section "start and operation"

START AND OPERATION - USERS GUIDE

Please operate the stove as following
(refer to stove structure figure and electrical control figure):

Check the box, pellet grate bar, ash pan then adjust to proper position.

OPERATIONS INSTRUCTIONS – QUICK REFERENCE GUIDE

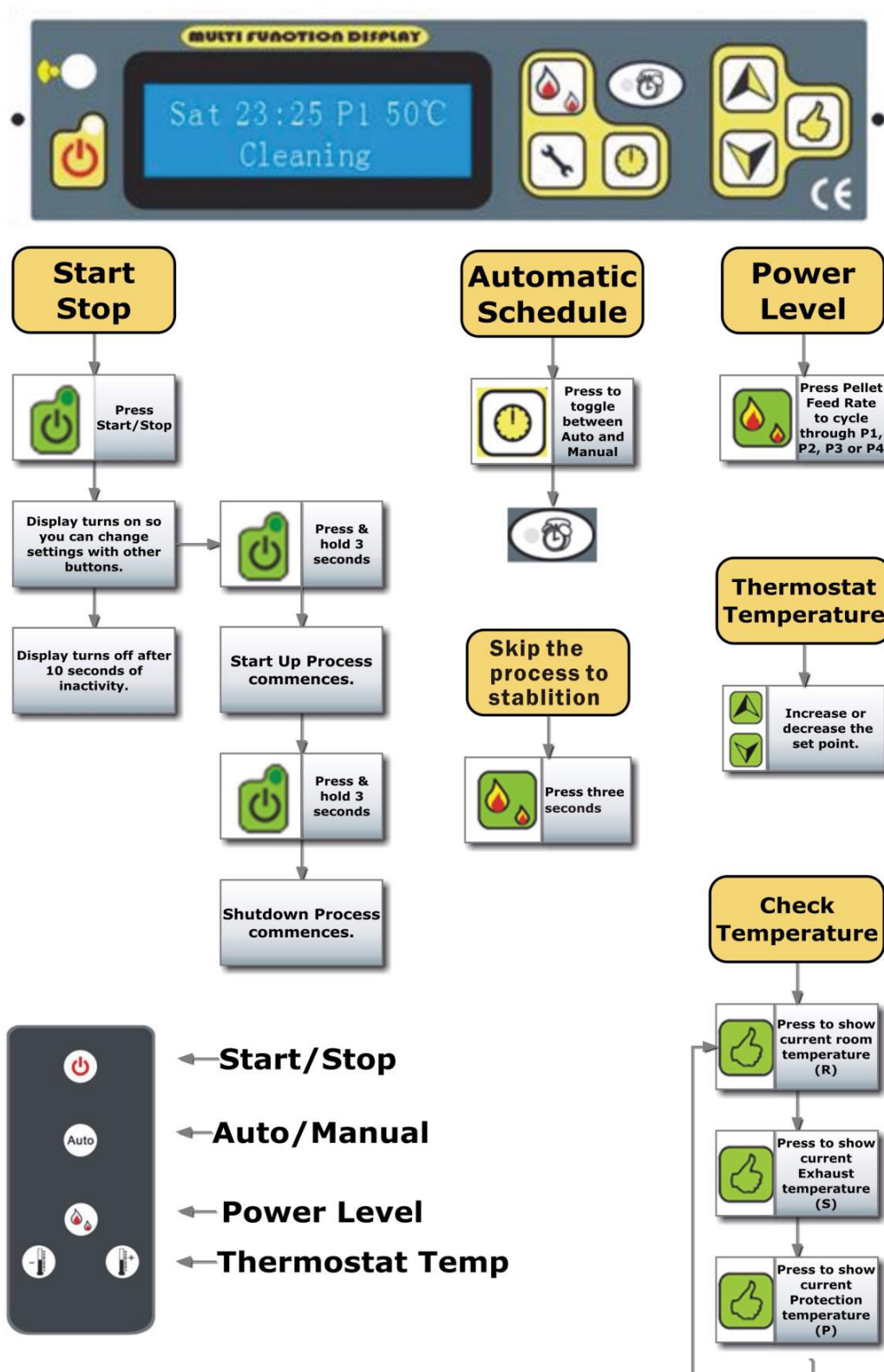

ON/OFF

1. Turning the heater on and off is performed with the ON/OFF button .

After switching on, the message, „CLEANING“ will be shown in order to clean the fire pot.



2. The start-up cycle, which has the duration of about 5-15 minutes, is necessary for the auger to carry the pellets to the burn pot, (depends on the heater). The start-up cycle is shown in the display as shown in the previous picture and then.



3. During the second phase 'FEEDING' the chimney verification operations are done and the pellets will be loaded in the burn pot. The successive phase will be shown by the display with the word "Lighting". This state remains up to when the smokes temperature doesn't exceed the planned threshold.



4. When the Lighting phase is finished, some minutes will be necessary for the flame stabilization. This phase is shown by the word „STABILIZATION“ which will stay indicated on the display and will indicate the maintenance phase of the achieved operational status.

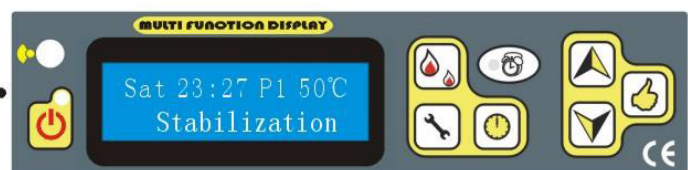

5. For turning off, push  .
The display will show:



6. After the temperature in the stove is cold enough, the word ,GOODBYE' is displayed.





ATTENTION:

During the flame switching off phase and exchanger cooling, you should not switch the stove on again until the cycle ends; this state is signalized by the display 'SWITCHING OFF'

HOWEVER, it is possible to switch off the heater in every functioning phase.

Turning off the heater is done by pressing the button ON/OFF  for two seconds; **make sure the stove is under your supervision**, until "Stabilization". After you push the button the word „Cooling“ will show on the display.

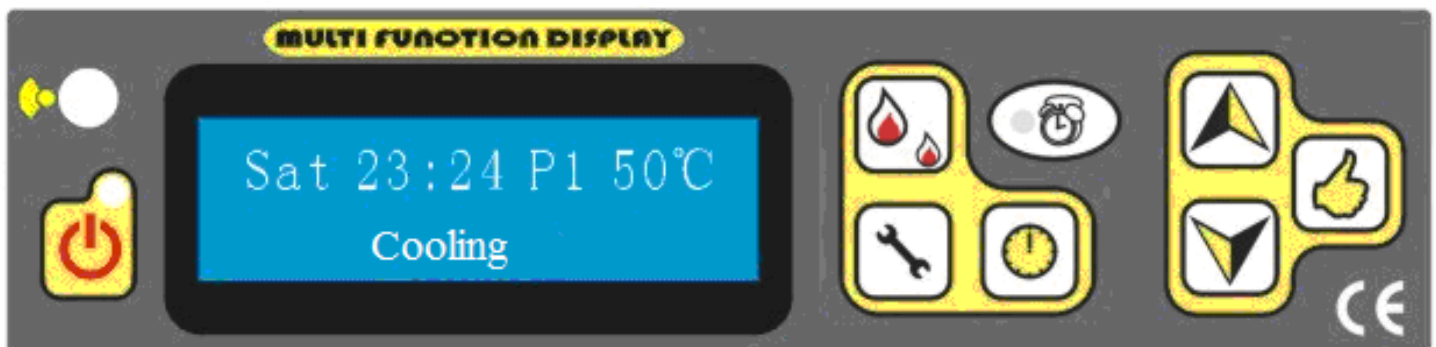

After the stove's temperature sinks, the stove will start again, Cleaning-feeding-lighting-stabilization.

How to make the stove skip to the process Stabilization when you think the flame is ok and/or the stove can work properly?

Push  for 3 seconds, and then it will turn directly to Stabilization.



ATTENTION:

If the heater is switched off, the flame will continue burn until the fuel exhaustion in the melting pot, this will happen in automatically, this can last up to 5-8 minutes.

The switching off phase is displayed by the message 'SWITCHING OFF'. This will show up to the end of the operation. Whether the heater is switched on or not. The display will display the hour, the power, and the planned set temperature.



NOTE:

Before first usage it is necessary to put a hand of pellets to the fire pot.



NOTE:

if the ignition fails, the thermal control will shut off the stove automatically. Meanwhile, E2 (Error for the ignition failure), will be shown on the display. If you want to restart it, please check the stove as usually and clean the fire pot.

After that, push  to clear the word E2. Follow the above process to ignite and start again.

FLAME POWER VARIATION

Depending on the heating desired, fuel intake quantity can be adjusted from few to many by the fuel intake button.

For example: Pressing the button  the quantity can be changed, the display shows the selected power.

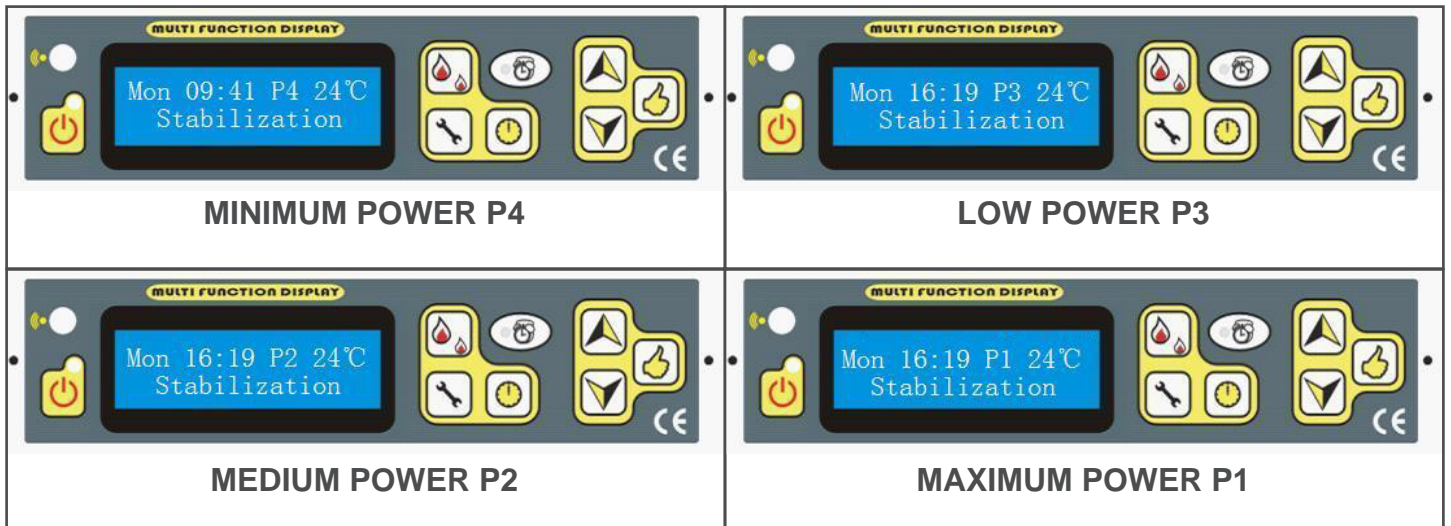

ECO STAGE

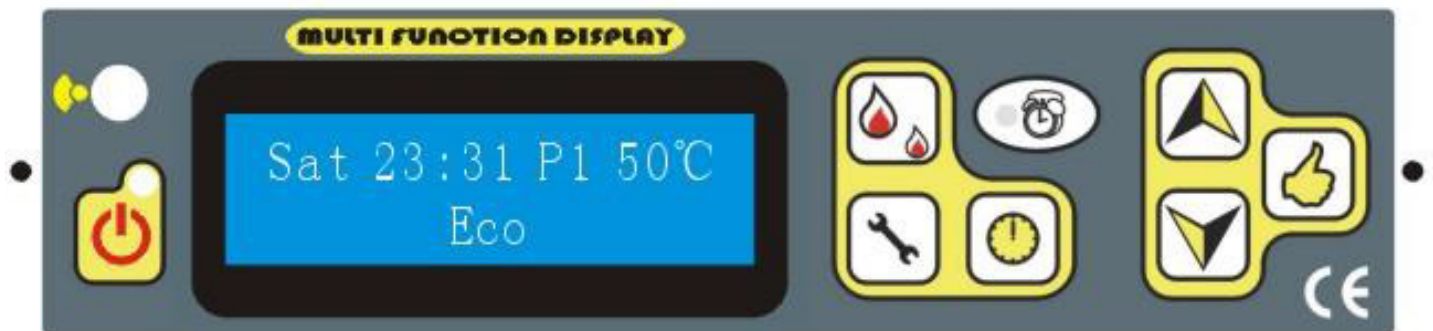

If the room temperature exceeds the set temperature, the stove is automatically stopped Eco1 or turns to minimum power in order to save energy Eco2.



If the room temperature drops below the set temperature (3 degrees), it will automatically switch on again or come back to the previous power level.

How to select these two functions will be shown later.

SELECTING AUTOMATIC AND MANUAL

Pressing the keys  the light shown on this button:  will be on or off. If the light is on, it signals that automatic program is selected. Otherwise it is manual.

DESIRED TEMPERATURE SETTING

Pressing the keys   on the display the temperature can be selected.

How to Check the Room temperature, Exhaust (Smoke) Temperature, Safety (Protection) Temperature which is located under the hopper.

By pressing the button 

The number with “R” is the room temperature.

The number with “S” is the temperature of the smoke

The number with “P” is the temperature for the protection.

For example:

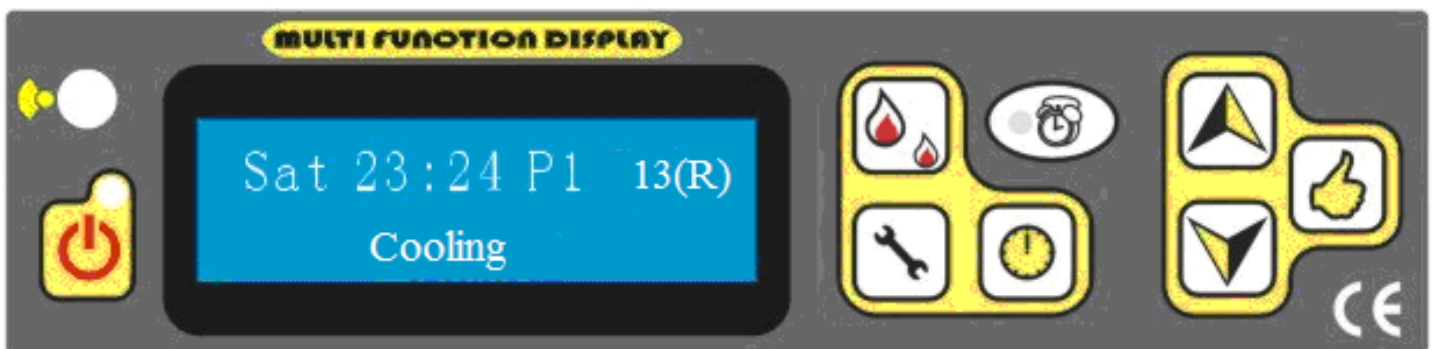

It means that the room temperature is 13 degree.

HOW TO SET DETAILS

SETUP – QUICK REFERENCE GUIDE

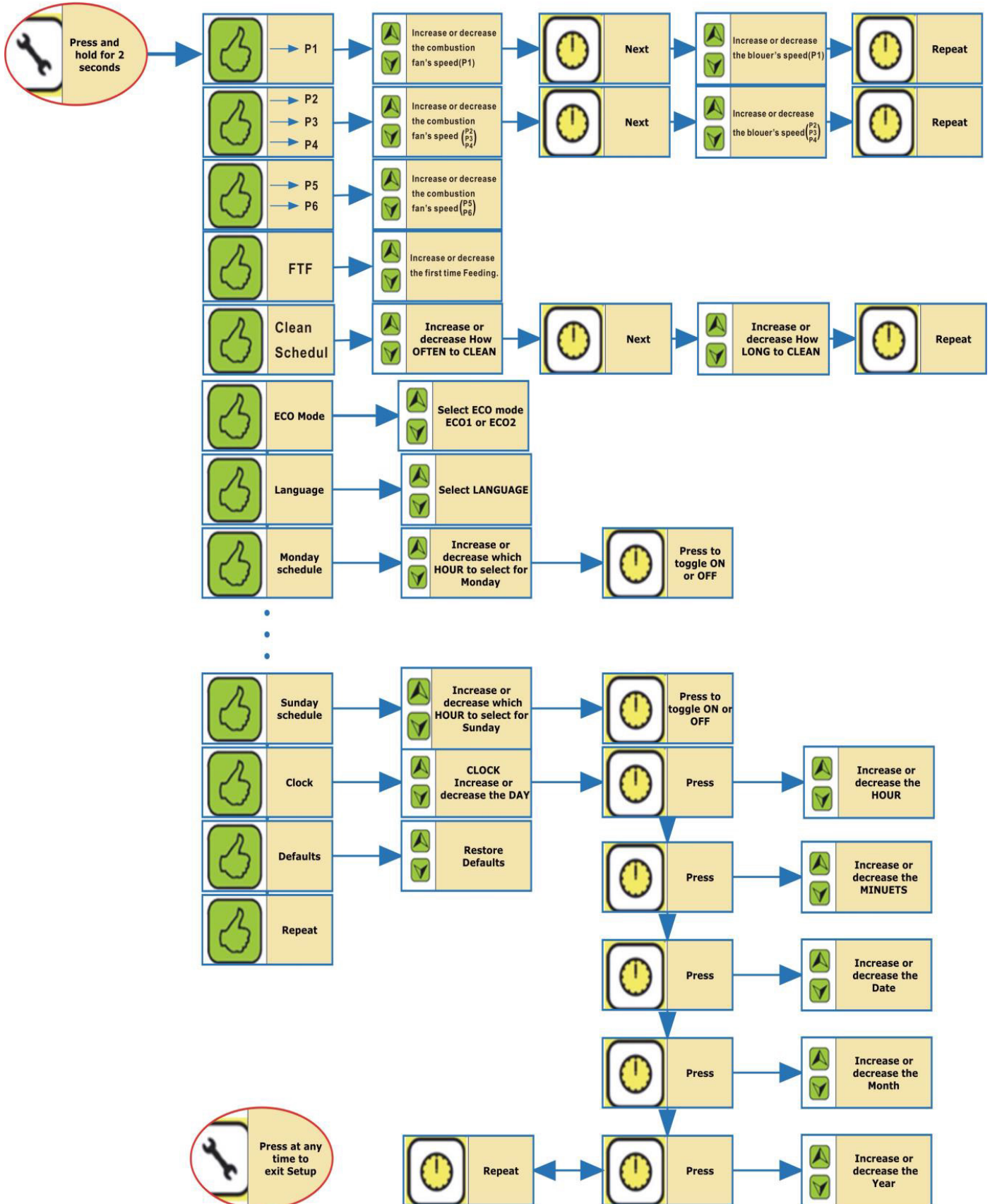



NOTE:

Press and hold the button  approx. 2 seconds to enter the setup menu.
Press the button again to exit the setting menu.

Press the button  to confirm the settings and move to the next setting point.
This will allow you to navigate through the setup menu.



This procedure applies to all subsequent setting points!

COMBUSTION FAN'S AND BLOWER'S SPEED SETTING

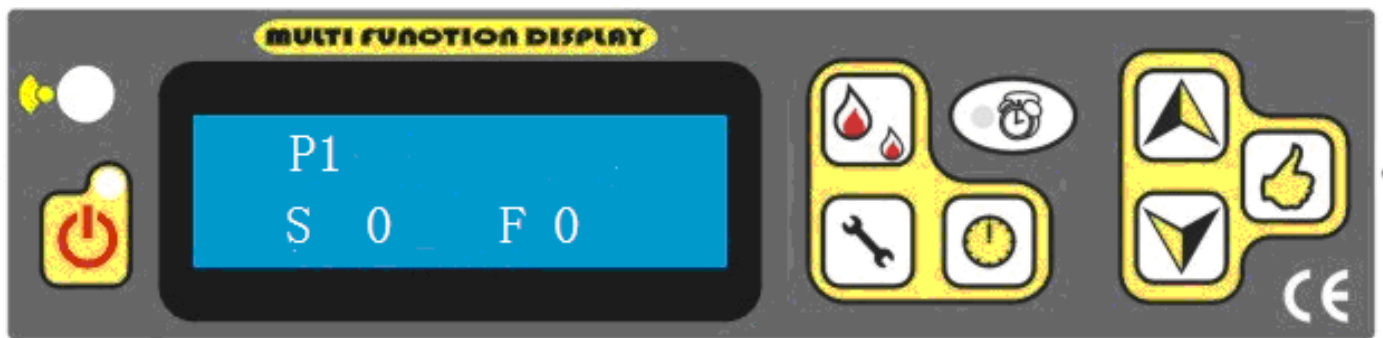
Press and hold the button  approx. 2 seconds to enter the setup menu.
The screen will display:



S= SMOKE(EXHUAST FAN) F=FAN(BLOWER)

Press  to move from "S 0" TO "F 0". Press  to adjust their speed.

Both of them can be adjusted from 20 to -20. Normally, factory setting is 0. 20 is max. and -20 is min.

Press  to save the setting and go to the subsequent setting points P2, P3 and P4.



After P4, it is P5, this data is related to the exhaust fan's speed of the "Cleaning" stage.
The adjustable range is also from 20 to -20.

The following is P6; this data is related to the exhaust fan's speed of the "Feeding", "Lighting" and minutes of "Stabilization" stage.

The adjustable range is also from 20 to -20.

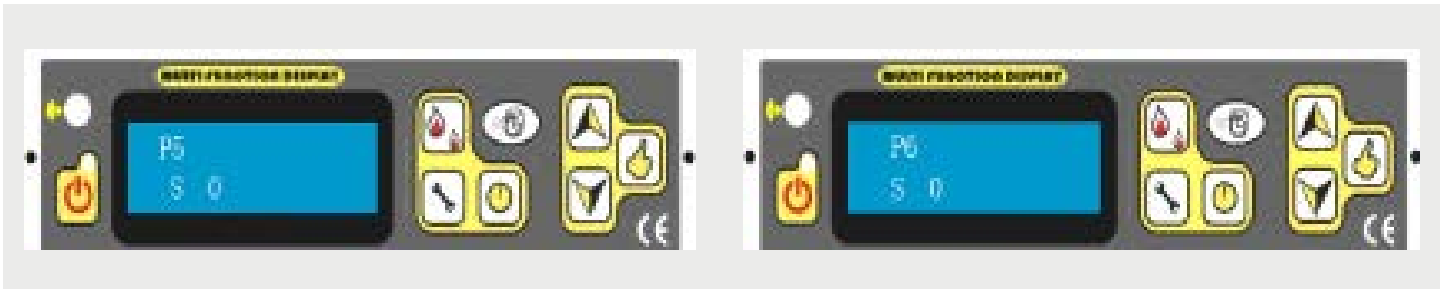



FIRST TIME FEEDING QUANTITY SETTING

Begin as described on page 18.

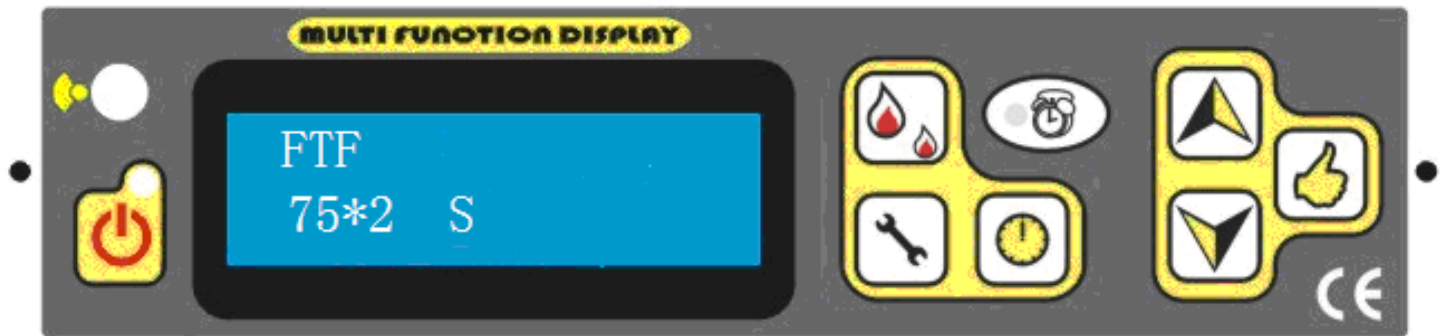
Press  until the following message appears:



FTF= FRIST TIME FEEDING 75*2 S MEANS 150 SECONDS' FEEDING TIME.

You can adjust thee time by pressing  .



To save the setting press  and enter the next setting.

CLOCK SETTING

Begin as described on page 18.

Press  until the following message appears:



You can select week or time by keys  also using  to change the day or  time.

To save the setting press  and enter the next setting.

CLEANING SETTING

Begin as described on page 18.

Press  until the following message appears:

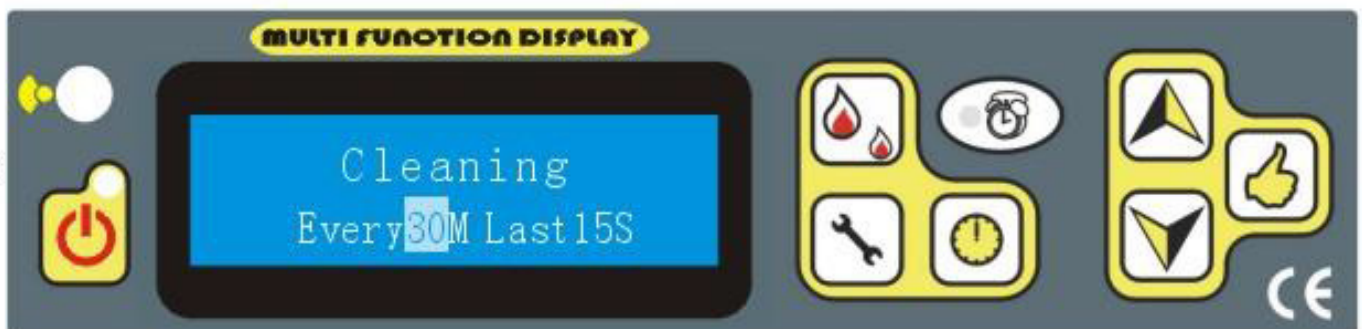

You can adjust the time of cleaning during the operation- "every X mins, last Y" Seconds to cleaning the burning pot

by the key . For example every 30mins Last 15 seconds:

To save the setting press  and enter the next setting.

TIMER SETTING

Begin as described on page 18.

Press until the following message appears:

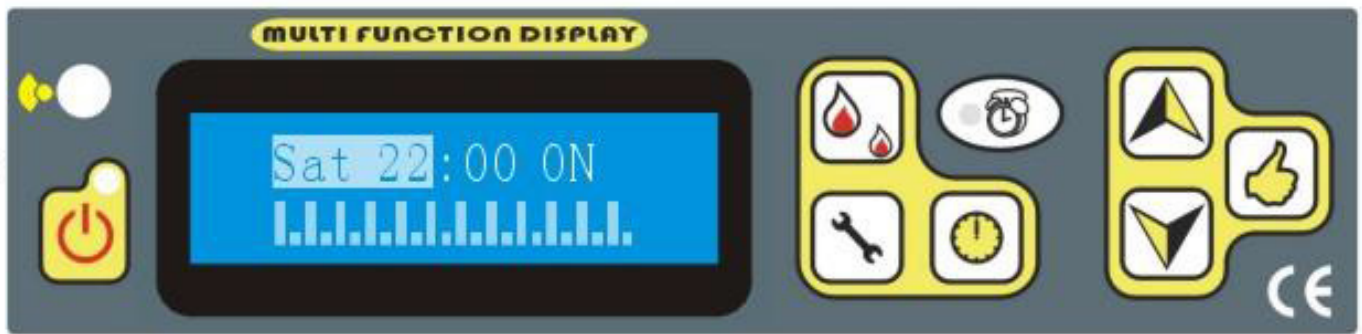

With this function you program the heater for a weekly programming, associating the switching on and the switching off at the pre fixed timetables.

You can program daily switching on and switching off for the whole week.

By keeping the key pushed you will find the attached instruction above,

then you can press to choose week days.

By pressing select hours, then press to choose the time for turning on or off.

On the above line the day is shown when it is programmed, the hour with the functioning cycle.

On the below line the programmed hour is displayed.

- The lower one is off, higher one is on, which also shows on the superior line

To save the setting press and enter the next setting.

LANGUAGE SETTING

Begin as described on page 18.

Press until the following message appears:

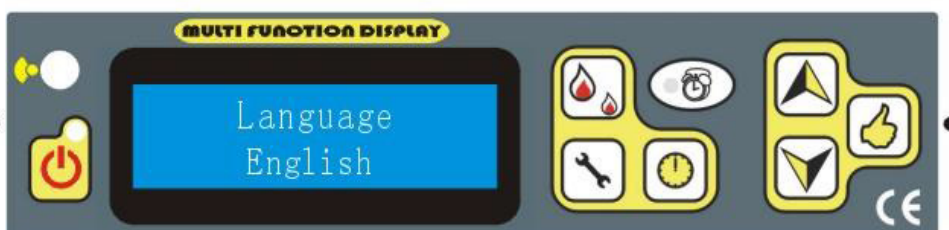

With this function you can select the language. By pressing the key



To save the setting press and enter the next setting.

ECO MODE SETTING

Begin as described on page 18.

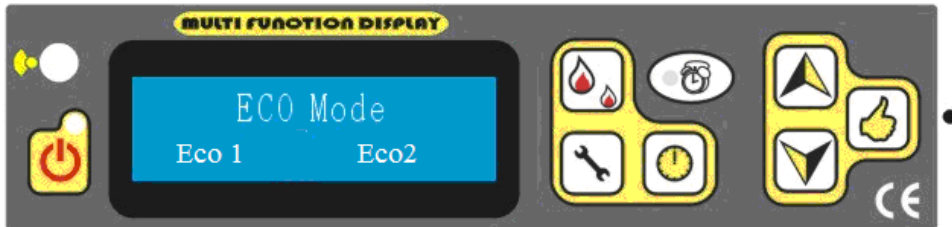
Press  until the following message appears:



Press the key  ,to select the Mode 1 or Mode 2

Mode 2 is for turning to minimum power, while mode 1 is for stopping the stove.



To save the setting press  and enter the next setting.

RESTORE DEFAULTS SELECT

Begin as described on page 18.

Press  until the following message appears:



With  , you can choose Yes, Or No. "Yes"- resets factory settings "NO" - use the data you have
 changed.

To save the setting press  and enter the next setting.

Press the key  to finish programming.



ATTENTION!!!

It means the fire has gone out automatically during the operation, when the exhaust gas temperature is lower than 40-45 degree.

Such as:

1. There is no fuel in the hopper.
2. Auger motor is broken and stops feeding the fuel.



It means Igniter failure at the beginning.

Such as:

1. There is clinker in fire pot.
2. The fire pot has not been put in correctly.
3. The switch that is located beside the combustion fan to test the exhaust gas temperature sensor is broken.
4. The igniter is broken



It means there is an earthquake during the operation time or the stove has been tilted.

Only for the Japanese version.



Problem with the temperature sensor.

Unplugged, broken or water temperature is too high (This function is only for the pellet stove with hot water).

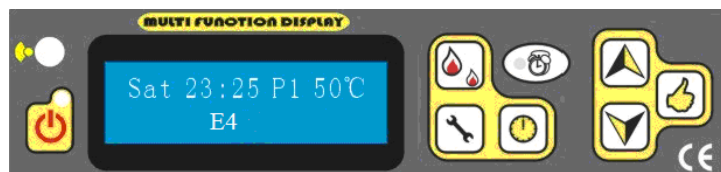

It means that there are some problems with vacuum. Such as: door has not been closed properly; Combustion fan's speed cannot accelerate; There is some leakage in the stove or the exhaust pipe is blocked.



It means that the high temperature sensor, which is located below the hopper, has some problem.

- Such as:
1. the switch is broken,
 2. The temperature is too high so that the stove does not run properly.



During the operation, the stove is interrupted by power cut.

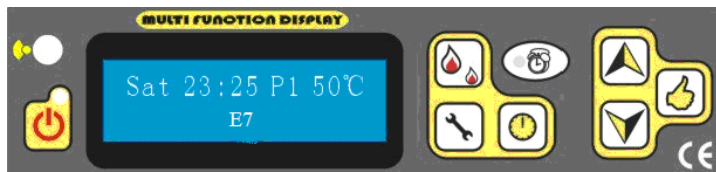

It means you need to clean the stove.

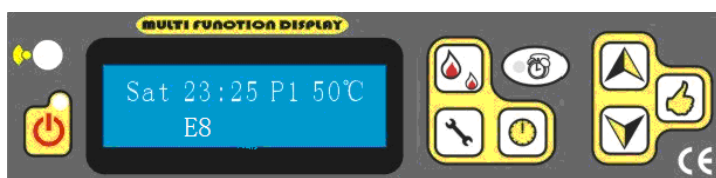

If everything is fine, you can press  to delete the Error code.



ATTENTION!!!

If showing following words when you start the stove:

It means temperature sensor 1 (exhaust gas temperature sensor) - short-circuit.

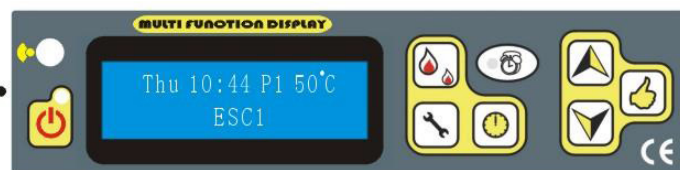

It means temperature sensor 1 is open-circuit.

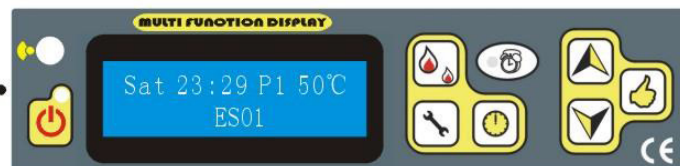

It means temperature sensor 2 (safety temperature sensor below the hopper) - short-circuit.

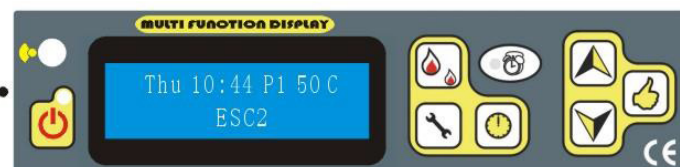

It means temperature sensor 2 is open-circuit.

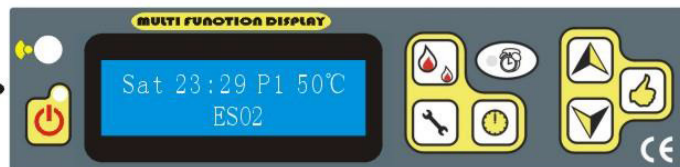

It means temperature sensor 3 (sensor for testing the room temperature, which is located on the rear panel) - short-circuit.

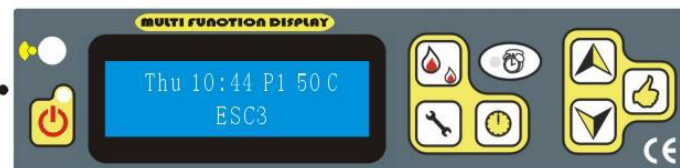

It means temperature sensor 3 is open-circuit.



SAFETY

POWER FAILURE

After the power failure, the display will be show E7. If short power failure, you can manually go back to „Stabilization“. Clear the E7 by „okay button“, restarting the stove and pressing „fire button“ for 3 seconds



During power failure a small amount of smoke may be emitted. This does not last for more than three to five minutes and does not present safety risks.

POWER INPUT SOCKET (contains the main fuse)).

ELECTRIC EXCESS-CURRENT SHUT OFF

The device is protected against excess current by a main fuse (on the rear of the device)

The following is a list of main components and their functions:

IGNITER

The STOVE comes equipped with an automatic igniter for lighting the fuel when the stove is in feeding and lighting mode.

VACCUM SWITCH

The STOVE has s vacuum switch located behind the left door, fastened to the base.

If a low pressure is created in the firebox by a leak, opening the front door, a blocked flue, or unsealed ash drawer (some models), the vacuum switch will sense it and cause the stove to go into a shutdown mode by showing E5.

AUGER AND AUGER MOTOR

The 2 RPM auger motor turns the auger, lifting pellets up the auger tube.

The pellets are then dropped down a tube and into the firepot.

The auger motor is controlled by the control board.

PROTECT TEMPERATURE SENSOR TO AVOID OVERHEATING

A safety temperature switch switches the stove off automatically if it overheats, after the stove has cooled down. Meanwhile it shows E6.

Whether the heating operation is continued or not depends on the remaining embers in the fire pan. After you remove the Error Code by „Okay button“, If re-ignition does not occur when the fuel supply recommences, then the out of operation program (cleaning , lag phase) is carried out.

According to the pre-set mode the stove must be re-started.



CAUTION:

If overheating has occurred then maintenance or cleaning work must be carried out.

EXHAUSTED TEMPERATURE SENSOR FUNCTION AS LOW TEMPERATURE SWITCH OFF

If the stove cools down below a minimum temperature the stove will switch off. This switch off can also occur if pre-heating is too slow.

6. CLEANING AND MAINTENANCE



CAUTION:

- Only work on the stove when the main plug has been removed from the socket.
- During assembly do not drop any items (screws) etc. into the fuel container - they can block the conveyor auger and damage the stove.
- Your stove must be switched off and have cooled down before work is carried out.
- Not cleaning this unit will cause it to burn poorly and will void your stove's warranty.

The frequency with which your stove must be cleaned as well as the maintenance intervals depends on the fuel you use.

High moisture contents, ash, dust and chips can more than double the necessity of maintenance intervals.

We would like to point out once again that you should only use tested and recommended wooden pellets as a fuel.

Operating handle

Your new pellet stove comes with an operating handle that is used for opening or closing the grate door. Please use this operating handle for:

- Cleaning the fire pan; Loosening the pellets in the pellet container should they stick to the side walls

Wood as a fertilizer

Wood mineral residue (approx. 1 -2%) remains in the combustion chamber as ash. This ash is a natural product and is an excellent fertilizer for all plants in the garden. However the ash should be aged first and "quenched" with water



CAUTION:

Embers may be hidden in the ash – empty only into metal containers.

CLEANING THE FIRE PAN



CAUTION:
Clean fire pan daily.

Reassure that ash or clinker does not block the air feed openings. The fire pan can easily be cleaned inside the stove. After removing the pan the area underneath can be vacuumed clean.



If the stove is heated in continuous operation, then it must be switched off twice within 24 hours in order to clean the pan. (danger of flash back)



CAUTION:
Only in a cold state, when the embers are extinguished!
Check the pan for correct seating.
Check that the pan is correctly seated.

CLEANING THE GRATE DOOR GLASS

The best way to clean the grate door glass is using a damp cloth with small amount of ash from the firebox.

Stubborn dirt can be removed using a special cleaner that can be purchased from your specialist stove dealer.

CLEANING THE FLUE GAS PASSAGE WAYS

Cleaning the flue passageways should be done at least once a year.

Burning high ash pellets may require this cleaning to be done more often.

Clean these passageways only when the stove and ash are cold.

Do not start a fire in the vacuum cleaner by vacuuming up hot ash.

On each side of the stove there are two access covers (see the following picture) that can be removed by unscrewing the two 5/32" allen head screws.

Insert a cleaning brush in the openings to loosen any ash buildup and use a vacuum cleaner to remove the loosened ash.

Reinstall the covers when cleaning is complete.

There are also two more access holes located behind the ash drawer.

Remove the ash drawer (see the previous page) and loosen the two 5/32" allen head screws shown as D in the drawing below.

Rotate the covers over the access holes and use a brush and vacuum to clean the ash.

Rotate the covers back over the holes and tighten the screws. Front View Looking into the Ash Drawer Cavity with the Ash Drawer Removed.

HOW TO CLEAN THE STOVE

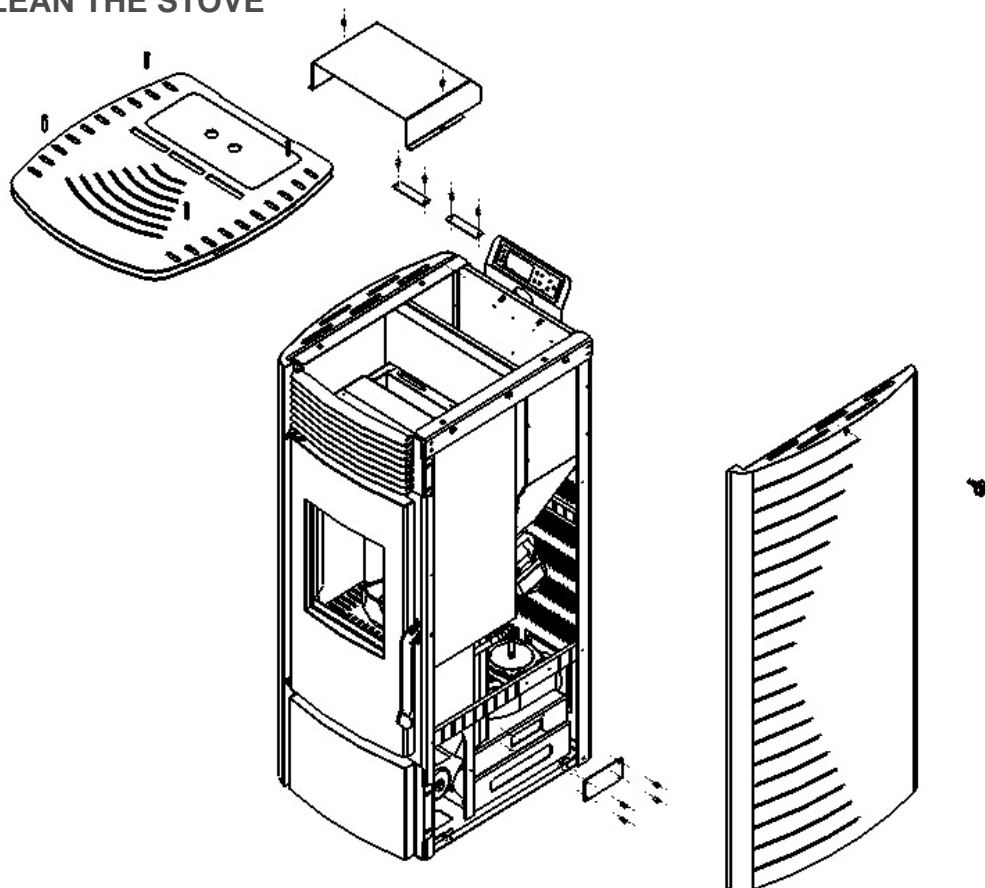

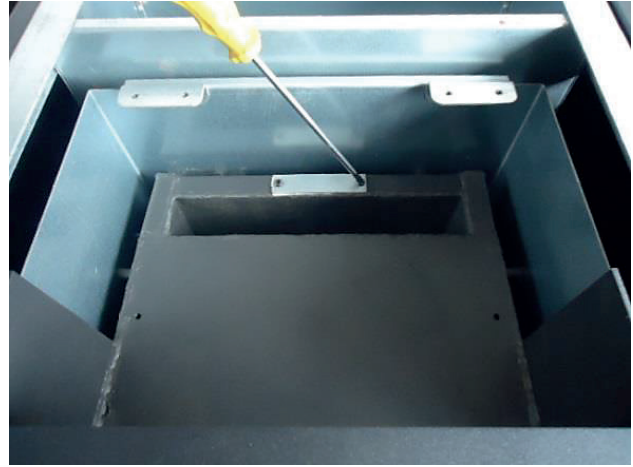
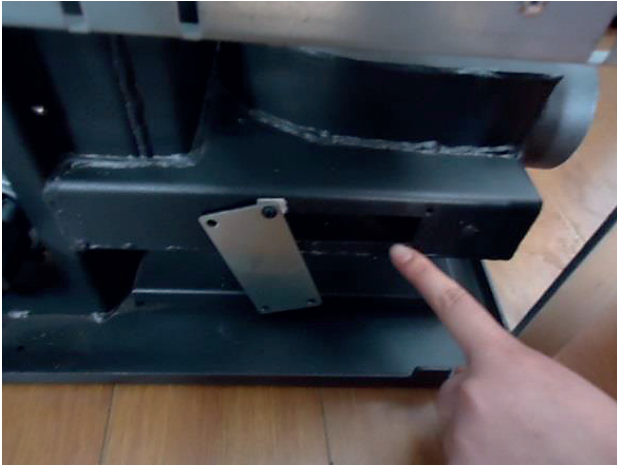

CLEANING THE CONVECTION BLOWER

To clean the convection blower, disconnect the stove power cord from the electrical outlet. Remove the side panels and rear panel (For all models) (and front bottom cover for NB-PI, NB-PS, NB-P01, NB-PE09).

A vacuum can be used to remove any dust accumulation on the blower's blades or inside the blower duct. Be careful to not damage the blower's blades during cleaning.

CLEANING THE VENT PIPE

Soot and Fly ash: Formation and Need for Removal

The products of combustion will contain small particles of fly ash that will collect in the exhaust venting system and restrict the flow of the flue gases. Incomplete combustion, such as occurs during start up, shutdown, or incorrect operation of the room heater will lead to some soot formation which will collect in the exhaust venting system.

The exhaust venting system should be inspected at least once every year to determine if cleaning is necessary. Sweep the pipe as needed. A tee and the cleanout in the vent system attached to the stove's flue collar will facilitate this cleaning.

Required Cleaning Schedule after Number of Bags Burned

Burn Pot = 10 bags

Ash Drawer = 50 bags

Flue Fan = 100 bags

Blower = 100 bags



NOTE:

Cleaning schedule will vary depending on quality of pellets used. Burned high ash pellets used. Burned high ash pellets will require more frequent cleaning.

7. TROUBLESHOOTING

HOW TO REPLACE INGITION BAR AND AUGER SYSTEM

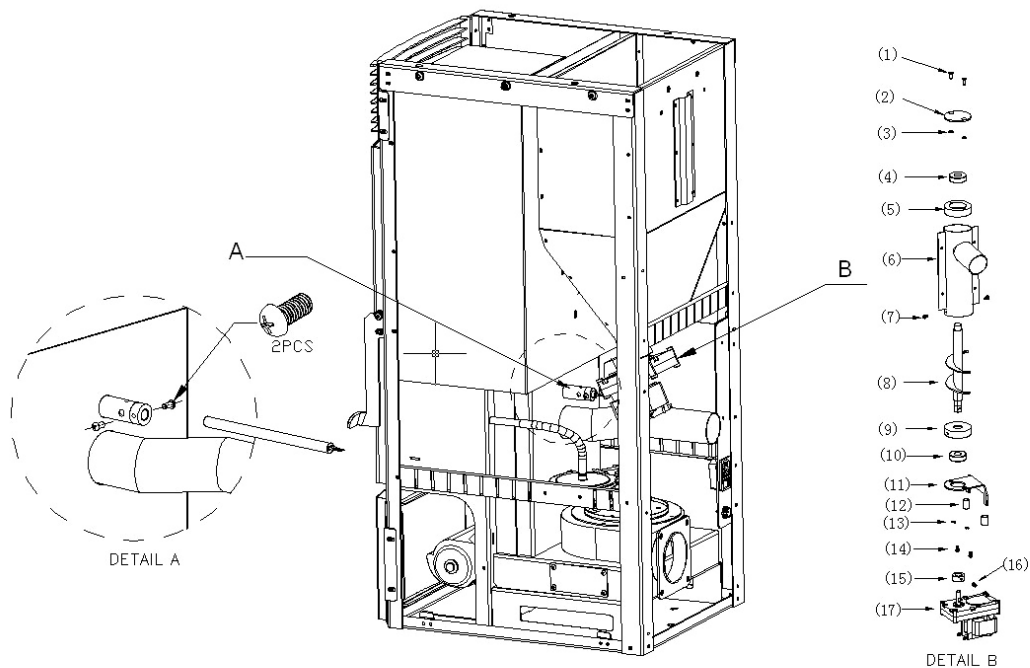

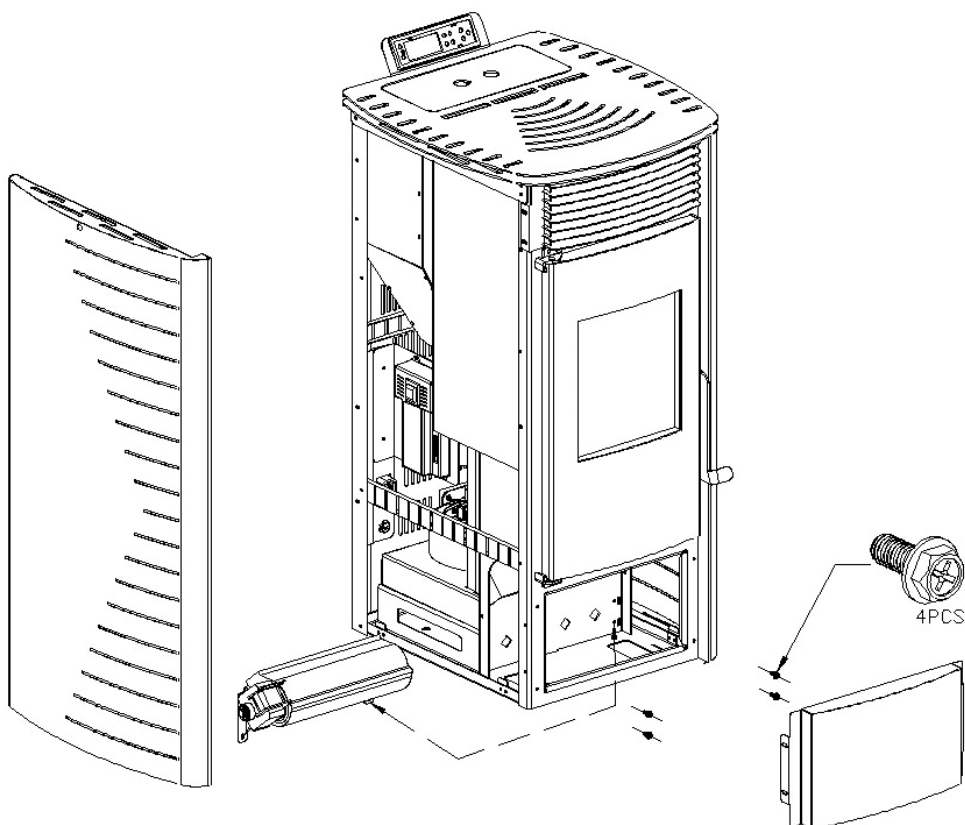

HOW TO REPLACE THE ROOM FAN (BLOWER)

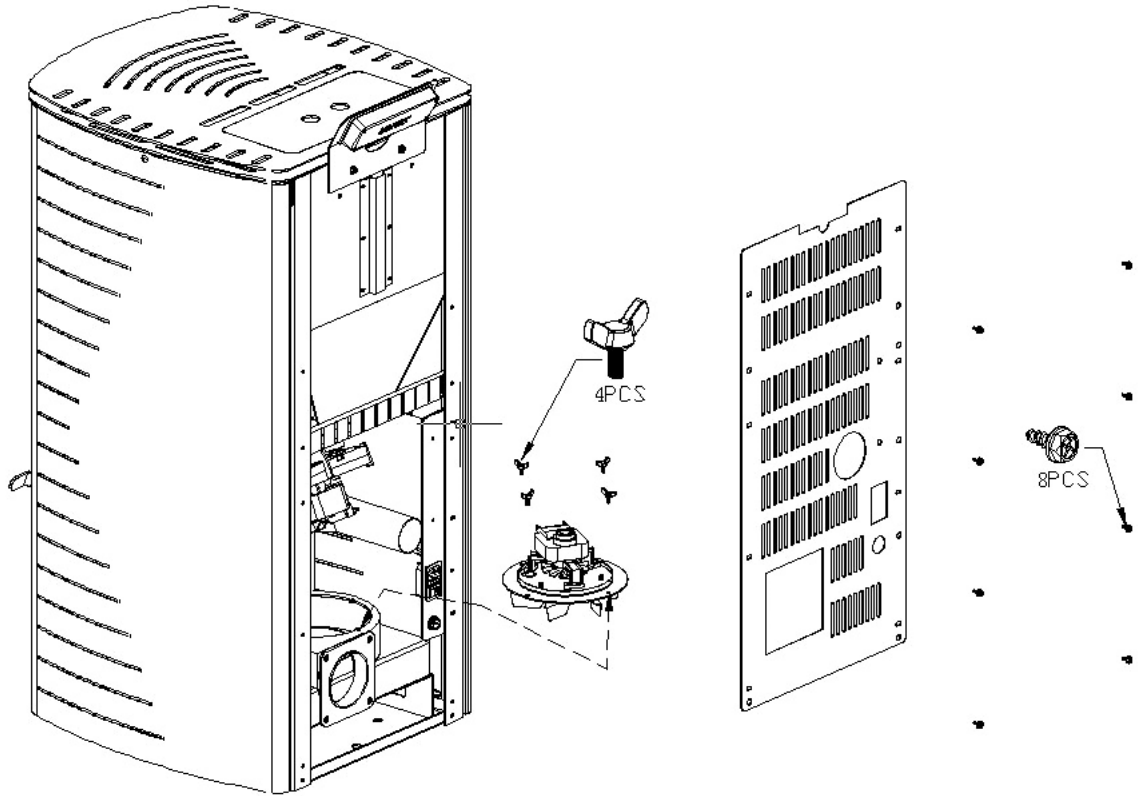

HOW TO REPLACE THE COMBUSTION FAN



The general troubles, the possible reasons and the solutions are as following.
After solving problems start the stove again:

Problem	Reason	Solution
<p>1. The start light or display does not light when power is on</p>	<p>No power in stove or in the control panel.</p>	<p>Check the power and wires.</p> 
	<p>Fuse is broken</p>	<p>Replace the fuse</p> 
<p>2. The blower doesn't work after pressing the start bottom.</p> <p>If after stabilization, it doesn't work, there must be something wrong</p>	<p>It is normal. It will start automatically when the temperature is above 30 degrees on the venting pipe.</p>	<p>Please wait</p>
	<p>No power in stove or in the control panel.</p> <p>Or unplugged on the mother board</p> <p>The low temperature sensor is broken</p>	<p>Check the power and wires.</p> <p>Plug in</p> <p>Replace it</p>

Problem	Reason	Solution
<p>3. No feeding after 20 seconds of starting. There are three stages for the feeding process. Stage one is during the first several minutes, feeding is constant. „Feeding“ is showing on the LCD display Stage two is the following couple minutes, the feeding light is off.: „Light“ showing on the display The last stage is that feeding will be done every several seconds all the time after previous stages.</p>		
<p>A. For the first stage (during first several minutes)</p>	<p>Feed unit is blocked.</p>	<p>Check the auger is blocked or not.</p>
	<p>There is a problem with the connection between motor and auger</p>	<p>Check the screws between auger and motor if they are loose or not. Or the auger might jump out</p>
	<p>No fuel in the hopper</p>	<p>Fill the fuel into the hopper</p>
<p>B. For the second stage</p>	<p>It is normal</p>	<p>Please be patient</p>
<p>C. Regarding the last stage</p>	<p>Feed unit is blocked.</p>	<p>Check the auger is blocked or not.</p>
	<p>There is a problem with the connection between motor and auger</p>	<p>Check the screw between auger and motor if it is loose or not or the auger might jump out</p>
	<p>No fuel in the hopper</p>	<p>Fill the fuel into the hopper.</p>
<p>4. Feeding not properly A. too much wood pellet and cannot burn in time</p>	<p>The level of feeding speed is too high</p>	<p>Accelerate the combustion fan's speed or Feeding quantity</p>
<p>B. The fire is off, not enough wood pellets can be burned</p>	<p>The level of feeding speed is too low</p>	<p>Lower the combustion fan's speed or feeding quantity</p>
<p>5. After ignition the power is off 15 min later.</p>	<p>Pellet feeder unit is off or pellet is too little.</p>	<p>Check the pellet feeder unit and restart.</p>
	<p>30°C temperature switch breaks or the connection wires of the switch are loose.</p>	<p>Check the connection wires or change the 30°C temperature switch.</p>
	<p>Pressure Switch is broken in the stove</p>	<p>Replace or repair the device</p>

Problem	Reason	Solution
6. orange and lazy fire, piled pellet, carbon on the glass	Lack of air intake for burning.	Clean the block in gate bar. Check the door and window glass gasket sealed or not. Check the air intake pipe and venting pipe blocked or not, and clean it. Change to the big diameter pipes if pipes are too long to affect combustion. Raise the combustion fan's speed. Call the dealer to reset the program
7. The fire went out and power went off automatically.	The hopper is empty. No fuel feed. The fuel feed is too little. Low temperature switch (30°C) is wrong. Set temperature is reached	Put fuel into the hopper. refer to (2) Lower the speed of combustion fan Cool the stove at least 1 hour then operate again or change the low temperature switch (30°C). „ECO“ its normal, waiting, after the temperature is below set on, it will automatically switch on again
8. The blower still works after the stove is cool and fuel feed stops.	The low temperature switch (30°C) is broken.	Change this switch.
9. Not enough heat wind	Unqualified fuel Blower speed is too low or not running. Heat exchange tubes or flue pass are dirty.	Use the standard special pellet. Change the blower(Broken) or the mother board is broken Clean the heat exchange tubes or flue pass.
10. Showing „E5“ on the display	Vent pipe is blocked The door is opening or seal needs to be replaced The are some leakages	Shut down the stove, check the venting pipe Close the door or change the seal. Check it and repair it. Raise the combustion fan's speed to offer more pressure in the stove

EN

ELECTRICAL GENERATOR OPERATION

Your stove can be powered with a gas driven electrical generator. However, the generator's electrical regulator may not be compatible with the stove's electronics. The higher the quality of the generator, the greater the chance that it is compatible with the stove.

8. ELECTRONIC PLAN

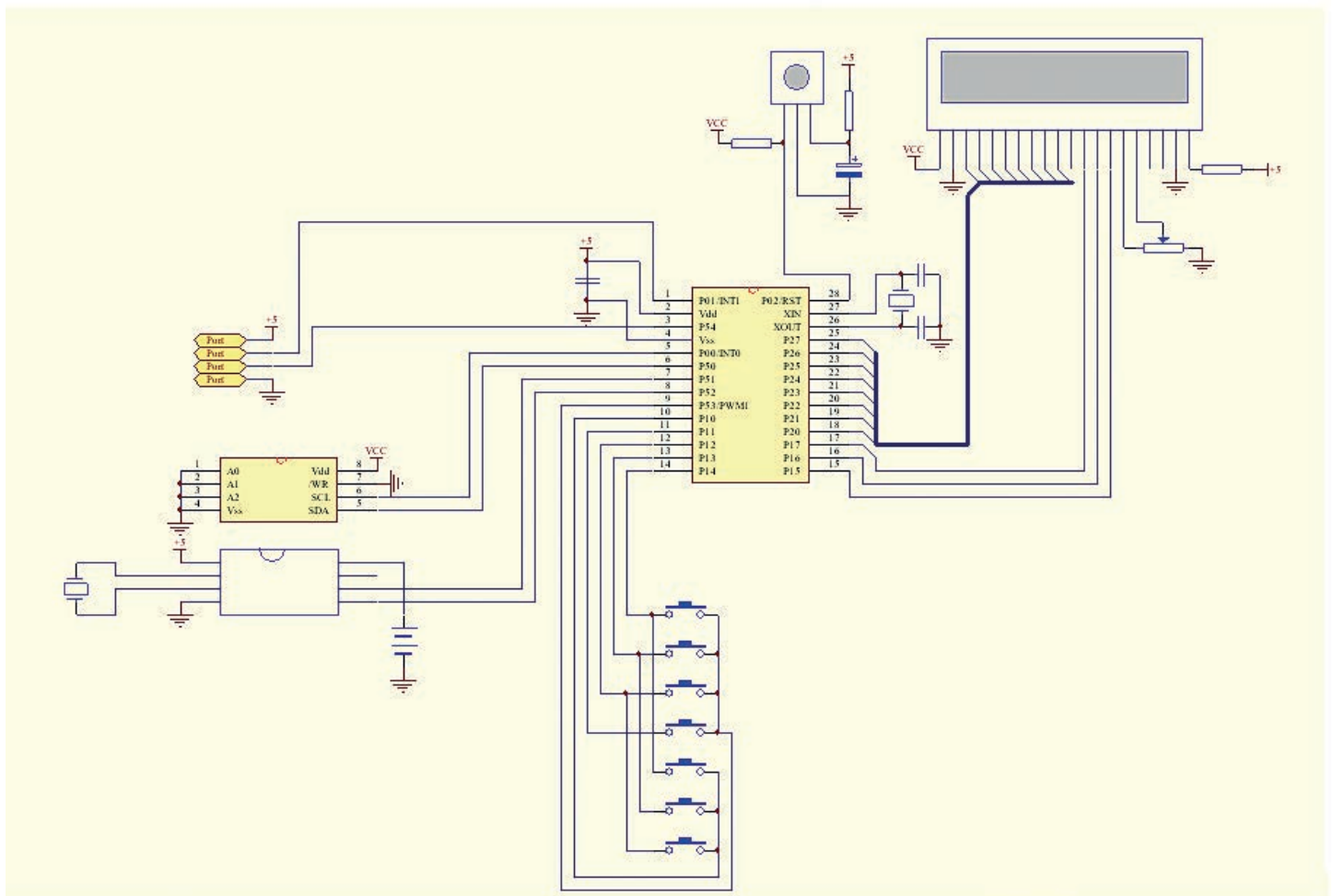

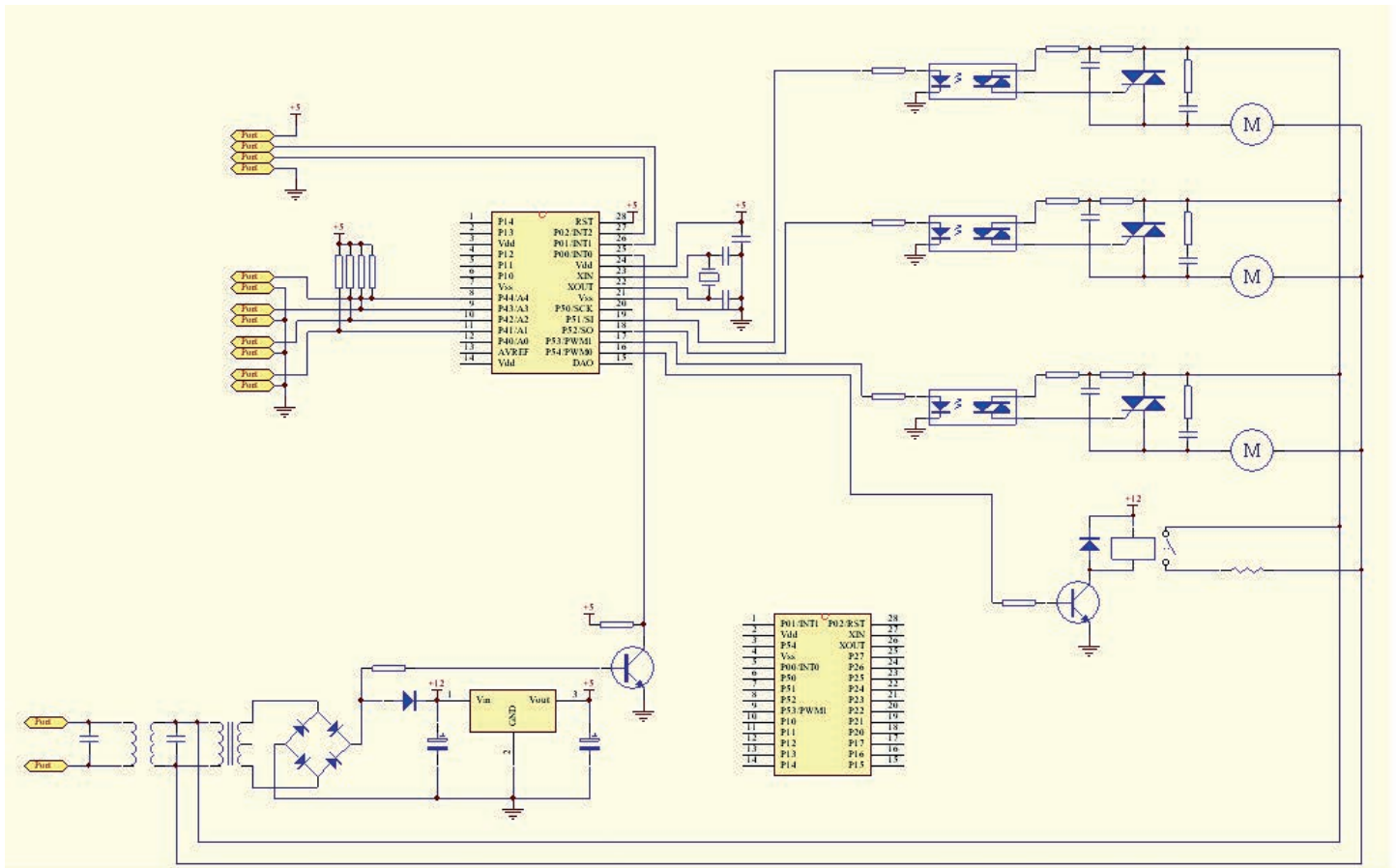

MANUFACTURER

Bargain24 AG
Sihleggstr. 23
8832 Wollerau
Switzerland

E-Mail: sales@bargain24.ch
Internet: www.bargain24.com

REPRESENTATIVE

eFulfillment GmbH
Ikarusallee 15
30179 Hannover
Germany

The right to make technical and design modifications
in the course of continuous product development remains reserved.

Declaration of Performance

According to Annex III of the Regulation (EU) 305/2011
N°KEN001P06

1. Unique identification code of the product type: **Nemaxx P6**
2. Type, batch or serial number or any other element allowing identification of the construction product as required pursuant to Article 11(4): **Art. N°1759 / 6623 / 6624**
3. Intended use or uses of the construction product, in accordance with the applicable harmonized technical specification, as foreseen by the manufacturer: **Space heater without water heating**
4. Name, registered trade name or registered trade mark and contact address of the manufacturer as required in Article 11(5):

Bargain24 AG
Sihleggstr. 23
8832 Wollerau
Switzerland

5. Name and address of authorized representative:

EFulfillment GmbH
Ikarusallee 15
30179 Hannover
Germany

6. System or systems of assessment and verification of constancy of performance of the construction product as set out in Annex V: **System 3**
7. In case of the declaration of performance concerning a construction, product covered by a harmonised standard: **TÜV SÜD Industrie Service GmbH**
N°: 0036
Report: W-O 1403-02/14
8. In case of the declaration of performance concerning a construction product, for which a European Technical Assessment has been issued: **NA**

9. Declared performances:

Harmonized technical specifications	EN 14785:2006-09 / EN 14785:2007-10 Cor. 1
Key Features	Performance
Mechanical strength	passed
durability	passed
Fire safety	passed
Fire behavior	A1
Distance appliance from combustible materials	Back: 200mm Side: 200mm Front: 1000mm
Fire hazard by escaping combustibles	passed

Surface temperature	passed
Emission at nominal heat output	passed CO 0,006%
Electrical Safety	passed
Cleanability	passed
Maximum water operating pressure	--
Flue Gas temperature at nominal heat output	158°C
Heat output	
Range thermal output	3,3 – 5,3 kW
Space heating range	5,3 kW
Water heating capacity	-- kW
Efficiency	86,3% bei nominal heat output

10. The performance of the product according to numbers 1 and 2 corresponds to the declared performance according to number 9.

The manufacturer according to number 4 is solely responsible for the preparation of this declaration of performance.

Signed for and behalf of:

Name: Maximilian Friedery
Director of Bargain24 AG

Date: 05.12.2014



Signature

Declaration of Performance

According to Annex III of the Regulation (EU) 305/2011
N°KEN001P09

1. Unique identification code of the product type: **Nemaxx P9**
2. Type, batch or serial number or any other element allowing identification of the construction product as required pursuant to Article 11(4): **Art. N°1751 / 6625 / 6626**
3. Intended use or uses of the construction product, in accordance with the applicable harmonized technical specification, as foreseen by the manufacturer: **Space heater without water heating**
4. Name, registered trade name or registered trade mark and contact address of the manufacturer as required in Article 11(5):

Bargain24 AG
Sihleggstr. 23
8832 Wollerau
Switzerland

5. Name and address of authorized representative:

EFulfillment GmbH
Ikarusallee 15
30179 Hannover
Germany

6. System or systems of assessment and verification of constancy of performance of the construction product as set out in Annex V: **System 3**
7. In case of the declaration of performance concerning a construction, product covered by a harmonised standard: **TÜV SÜD Industrie Service GmbH**
N°: 0036
Report: W-O 1404-02/14
8. In case of the declaration of performance concerning a construction product, for which a European Technical Assessment has been issued: **NA**

9. Declared performances:

Harmonized technical specifications	EN 14785:2006-09 / EN 14785:2007-10 Cor. 1
Key Features	Performance
Mechanical strength	passed
Durability	passed
Fire safety	passed
Fire behavior	A1
Distance appliance from combustible materials	Back: 200mm Side: 200mm Front: 1000mm
Fire hazard by escaping combustibles	passed

Surface temperature	passed
Emission at nominal heat output	passed CO 0,007%
Electrical Safety	passed
Cleanability	passed
Maximum water operating pressure	--
Flue Gas temperature at nominal heat output	169°C
Heat output	
Range thermal output	3,8 – 7,1 kW
Space heating range	7,1 kW
Water heating capacity	-- kW
Efficiency	86,2% bei nominal heat output

10. The performance of the product according to numbers 1 and 2 corresponds to the declared performance according to number 9.

The manufacturer according to number 4 is solely responsible for the preparation of this declaration of performance.

Signed for and behalf of:

Name: Maximilian Friedery
Director of Bargain24 AG

Date: 05.12.2014



Signature

Declaration of Performance

According to Annex III of the Regulation (EU) 305/2011
N°KEN001P12

1. Unique identification code of the product type: **Nemaxx P12**
2. Type, batch or serial number or any other element allowing identification of the construction product as required pursuant to Article 11(4): **Art. N°1752 / 6627 / 6628**
3. Intended use or uses of the construction product, in accordance with the applicable harmonized technical specification, as foreseen by the manufacturer: **Space heater without water heating**
4. Name, registered trade name or registered trade mark and contact address of the manufacturer as required in Article 11(5):

Bargain24 AG
Sihleggstr. 23
8832 Wollerau
Switzerland

5. Name and address of authorized representative:

EFulfillment GmbH
Ikarusallee 15
30179 Hannover
Germany

6. System or systems of assessment and verification of constancy of performance of the construction product as set out in Annex V: **System 3**
7. In case of the declaration of performance concerning a construction, product covered by a harmonised standard: **TÜV SÜD Industrie Service GmbH**
N°: 0036
Report: W-O 1405-02/14
8. In case of the declaration of performance concerning a construction product, for which a European Technical Assessment has been issued: **NA**

9. Declared performances:

Harmonized technical specifications	EN 14785:2006-09 / EN 14785:2007-10 Cor. 1
Key Features	Performance
Mechanical strength	passed
durability	passed
Fire safety	passed
Fire behavior	A1
Distance appliance from combustible materials	Back: 200mm Side: 200mm Front: 1000mm
Fire hazard by escaping combustibles	passed

Surface temperature	passed
Emission at nominal heat output	passed CO 0,006%
Electrical Safety	passed
Cleanability	passed
Maximum water operating pressure	--
Flue Gas temperature at nominal heat output	178°C
Heat output	
Range thermal output	5,4 – 10,5 kW
Space heating range	10,5 kW
Water heating capacity	-- kW
Efficiency	88,6% bei nominal heat output

10. The performance of the product according to numbers 1 and 2 corresponds to the declared performance according to number 9.

The manufacturer according to number 4 is solely responsible for the preparation of this declaration of performance.

Signed for and behalf of:

Name: Maximilian Friedery
Director of Bargain24 AG

Date: 05.12.2014



Signature



Industrie Service

Choose certainty.
Add value.

Test report

on the initial type test of a residential space heating appliance
fired by wood pellets according to DIN EN 14785

Test laboratory	TÜV SÜD Industrie Service GmbH Feuerungs- und Wärmetechnik Notified Body 0036 according to CPR	Date: 2014-11-04 Our reference IS-TAF- MUC/wei Report no. W-O 1403-02/14 Order no. 2279554
Subject of test	Roomheater according to DIN EN 14785	
Type	Nemaxy P6 Intended use: space heating Fuel: wood pellets	Document: WO14030214_bargain24_P6. doc Page 1 This document includes 8 pages and 28 enclosures
Customer	Bargain24 AG Sihleggstr. 23 8832 Wollerau Schweiz	
Scope of order	Initial type test in the conformity assessment procedure according to Regulation (EU) No. 305/2011 (CPR)	Excerpts from this document may only be reproduced and used for advertising purposes with the express written approval of TÜV SÜD Industrie Service GmbH.
Expert	Dipl.-Ing. Dirk Weisgerber	
Period of Test	November 2013 to November 2014	The test results refer exclusively to the units under test.
Basis of test	DIN EN 14785:2006-09 DIN EN 14785 Berichtigung 1:2007-10	



Page 2 of 8
Our reference / date IS-TAF-MUC/we1 / 2014-11-04
Document: WO14030214_bargain24_P6.doc
Report no. W-O 1403-02/14



1 Summary

Customer	Bargain24 AG, Schweiz 8832 Wollerau
Subject of test	Roomheater fired by wood pellets according to DIN EN 14785
Intended use	Space heating
Fuel	Wood Pellets
Type	Nemaxx P6
General design	Body of the appliance: steel Cover of the appliance: steel cover Front fire door with small glass inset Integrated fuel hopper Combustion in burner pot Combustion air supply: induced draught fan Convection air with fan Automatically fed up with auger Automatic ignition Cleaning and deashing manual Grate integrated in the burner Ash drawer

Characteristics at nominal and partial heat output

		Nominal heat output	Partial heat output
Heat output	kW	5,3	3,3
Fuel rate	kg/h	1,2	0,8
CO-Emission (13% Vol. O ₂)	Vol. %	0,006	0,016
CO-Emission (13% Vol. O ₂)	mg/m ³	77	202
Dust-Emission (13% Vol. O ₂)	mg/m ³	27	66
Efficiency	%	86,3	88,7
Flue-gas temperature	°C	158	113
Flue-gas temperature behind the stove in the spigot	°C	203	145
Flue draught	Pa	12	10
Flue gas mass flow	g/s	5,6	4,4
Electrical connection		~ 230 V, 50 Hz	
Distance to combustible	cm	20 (rear wall) / 20 (side wall) 100 (front) / 0 (floor) 80 (top of stove to ceiling)	

Page 3 of 8
Our reference / date IS-TAF-MJC/wei / 2014-11-04
Document: WO14030214_bargain24_P6.doc
Report no. W-O 1403-02/14



Industrie Service

The essential characteristics according to appendix ZA.1 of DIN EN 14785 for room heaters fired by wood pellets were tested and the requirements are fulfilled, if the measures in clause 6 have been taken into account. This result is a prerequisite for performing the process of assessment of conformity and CE marking by the manufacturer.

Feuerungs- und Wärmetechnik

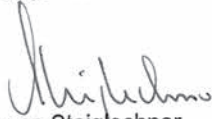

Johannes Steiglechner
Head of department
Feuerungs- und Wärmetechnik

Expert of Notified Body 0036
according to Regulation (EU)
No. 305/2011 (CPR)



Dirk Weisgerber



Industrie Service

Choose certainty.
Add value.

Test report

on the initial type test of a residential space heating appliance
fired by wood pellets according to DIN EN 14785

Test laboratory	TÜV SÜD Industrie Service GmbH Feuerungs- und Wärmetechnik Notified Body 0036 according to CPR	Date: 2014-11-04 Our reference IS-TAF- MUC/wei Report no. W-O 1404-02/14 Order no. 2279554
Subject of test	Roomheater according to DIN EN 14785	Document: WO14040214_bargain24_P9. doc Page 1
Type	Nemaxx P9 Intended use: space heating Fuel: wood pellets	This document includes 8 pages and 27 enclosures
Customer	Bargain24 AG Sihleggstr. 23 8832 Wollerau Schweiz	
Scope of order	Initial type test in the conformity assessment procedure according to Regulation (EU) No. 305/2011 (CPR)	Excerpts from this document may only be reproduced and used for advertising purposes with the express written approval of TÜV SÜD Industrie Service GmbH.
Expert	Dipl.-Ing. Dirk Weisgerber	
Period of Test	November 2013 to November 2014	The test results refer exclusively to the units under test.
Basis of test	DIN EN 14785:2006-09 DIN EN 14785 Berichtigung 1:2007-10	



Page 2 of 8
Our reference / date IS-TAF-MUC/wei / 2014-11-04
Document: WO14040214_bargain24_P9.doc
Report no. W-O 1404-02/14



Industrie Service

1 Summary

Customer	Bargain24 AG, Schweiz 8832 Wollerau
Subject of test	Roomheater fired by wood pellets according to DIN EN 14785
Intended use	Space heating
Fuel	Wood Pellets
Type	Nemaxy P9
General design	Body of the appliance: steel Cover of the appliance: steel cover Front fire door with small glass inset Integrated fuel hopper Combustion in burner pot Combustion air supply: induced draught fan Convection air with fan Automatically fed up with auger Automatic ignition Cleaning and deashing manual Grate integrated in the burner Ash drawer

Characteristics at nominal and partial heat output

		Nominal heat output	Partial heat output
Heat output	kW	7,1	3,8
Fuel rate	kg/h	1,8	0,9
CO-Emission (13% Vol. O ₂)	Vol. %	0,007	0,015
CO-Emission (13% Vol. O ₂)	mg/m ³	89	184
Dust-Emission (13% Vol. O ₂)	mg/m ³	23	23
Efficiency	%	86,2	90,2
Flue-gas temperature	°C	169	112
Flue-gas temperature behind the stove in the spigot	°C	223	151
Flue draught	Pa	12	10
Flue gas mass flow	g/s	7,1	4,3
Electrical connection		~ 230 V, 50 Hz	
Distance to combustible	cm	20 (rear wall) / 20 (side wall) 100 (front) / 0 (floor) 80 (top of stove to ceiling)	

Page 3 of 8
Our reference / date IS-TAF-MUC/wei / 2014-11-04
Document: WO14040214_bargain24_P9.doc
Report no. W-O 1404-02/14



Industrie Service

The essential characteristics according to appendix ZA.1 of DIN EN 14785 for room heaters fired by wood pellets were tested and the requirements are fulfilled, if the measures in clause 6 have been taken into account. This result is a prerequisite for performing the process of assessment of conformity and CE marking by the manufacturer.

Feuerungs- und Wärmetechnik

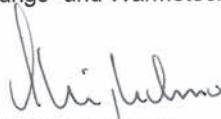

Johannes Steiglechner
Head of department
Feuerungs- und Wärmetechnik

Expert of Notified Body 0036
according to Regulation (EU)
No. 305/2011 (CPR)



Dirk Weisgerber



Industrie Service

Choose certainty.
Add value.

Test report

on the initial type test of a residential space heating appliance
fired by wood pellets according to DIN EN 14785

Test laboratory	TÜV SÜD Industrie Service GmbH Feuerungs- und Wärmetechnik Notified Body 0036 according to CPR	Date: 2014-11-04 Our reference IS-TAF- MUC/wel Report no. W-O 1405-02/14 Order no. 2279554
Subject of test	Roomheater according to DIN EN 14785	
Type	Nemaxx P12 Intended use: space heating Fuel: wood pellets	Document: WO14050214_bargain24_P12 .doc Page 1 This document includes 8 pages and 28 enclosures
Customer	Bargain24 AG Sihleggstr. 23 8832 Wollerau Schweiz	
Scope of order	Initial type test in the conformity assessment procedure according to Regulation (EU) No. 305/2011 (CPR)	Excerpts from this document may only be reproduced and used for advertising purposes with the express written approval of TÜV SÜD Industrie Service GmbH.
Expert	Dipl.-Ing. Dirk Weisgerber	
Period of Test	January to November 2014	The test results refer exclusively to the units under test.
Basis of test	DIN EN 14785:2006-09 DIN EN 14785 Berichtigung 1:2007-10	



Page 2 of 8
Our reference / date IS-TAF-MUC/wei / 2014-11-04
Document: WO14050214_bargain24_P12.doc
Report no. W-O 1405-02/14



1 Summary

Customer	Bargain24 AG, Schweiz 8832 Wollerau
Subject of test	Roomheater fired by wood pellets according to DIN EN 14785
Intended use	Space heating
Fuel	Wood Pellets
Type	Nemaxx P12
General design	Body of the appliance: steel Cover of the appliance: steel cover Front fire door with glass inset Integrated fuel hopper Combustion in burner pot Combustion air supply: induced draught fan Convection air with fan Automatically fed up with auger Automatic ignition Cleaning and deashing manual Grate integrated in the burner Ash drawer

Characteristics at nominal and partial heat output

		Nominal heat output	Partial heat output
Heat output	kW	10,5	5,4
Fuel rate	kg/h	2,6	1,2
CO-Emission (13% Vol. O ₂)	Vol. %	0,006	0,013
CO-Emission (13% Vol. O ₂)	mg/m ³	77	162
Dust-Emission (13% Vol. O ₂)	mg/m ³	22	42
Efficiency	%	88,6	93,5
Flue-gas temperature	°C	178	92
Flue-gas temperature behind the stove in the spigot	°C	232	124
Flue draught	Pa	12	10
Flue gas mass flow	g/s	7,6	4,9
Electrical connection		~ 230 V, 50 Hz	
Distance to combustible	cm	20 (rear wall) / 20 (side wall) 100 (front) / 0 (floor) 80 (top of stove to ceiling)	

Page 3 of 8
Our reference / date IS-TAF-MUC/wei / 2014-11-04
Document: WO14050214_bargain24_P12.doc
Report no. W-O 1405-02/14



The essential characteristics according to appendix ZA.1 of DIN EN 14785 for room heaters fired by wood pellets were tested and the requirements are fulfilled, if the measures in clause 6 have been taken into account. This result is a prerequisite for performing the process of assessment of conformity and CE marking by the manufacturer.

Feuerungs- und Wärmetechnik

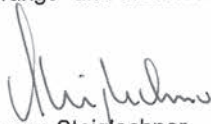

Johannes Steiglechner
Head of department
Feuerungs- und Wärmetechnik

Expert of Notified Body 0036
according to Regulation (EU)
No. 305/2011 (CPR)



Dirk Weisgerber